

L100 Pump

No	Base	Sales area	Model
1	L-V	Euro	L100V6DA1F1AA
		Asia	L100V6-PEYI
2	L-N	Global	L100N6DA1F1AA
		Asia	L100N6-PEYI

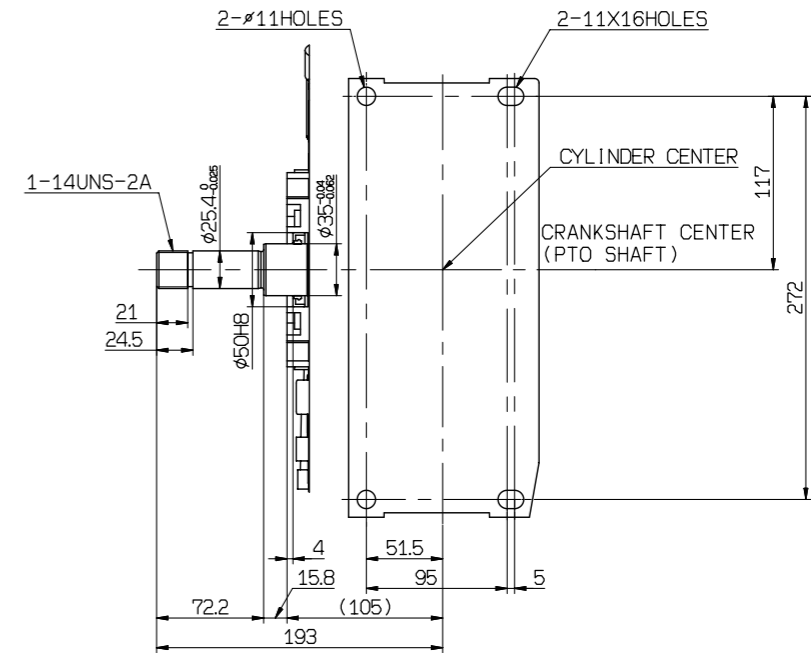

ENGINE MOUNTING PLATE AND PTO SHAFT
SEEN THROUGH FROM THE TOP OF THIS ENGINE

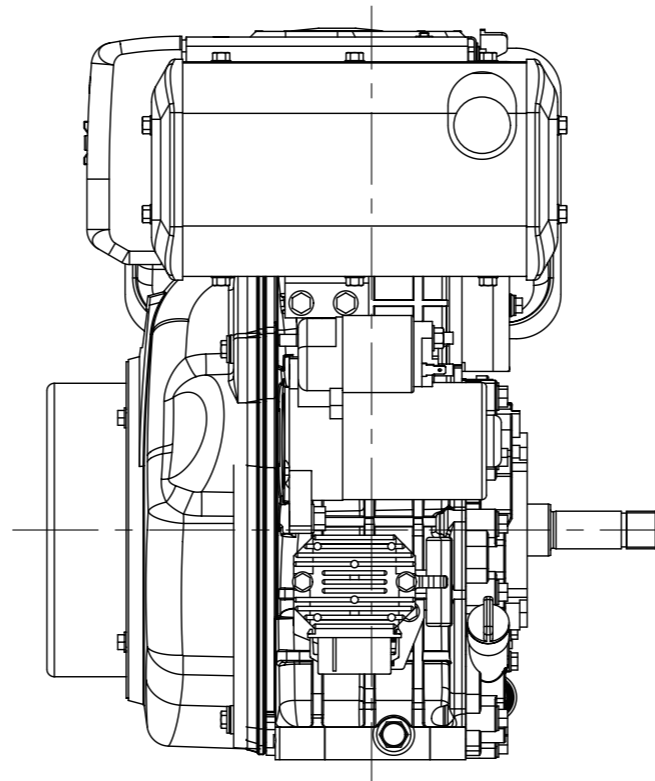
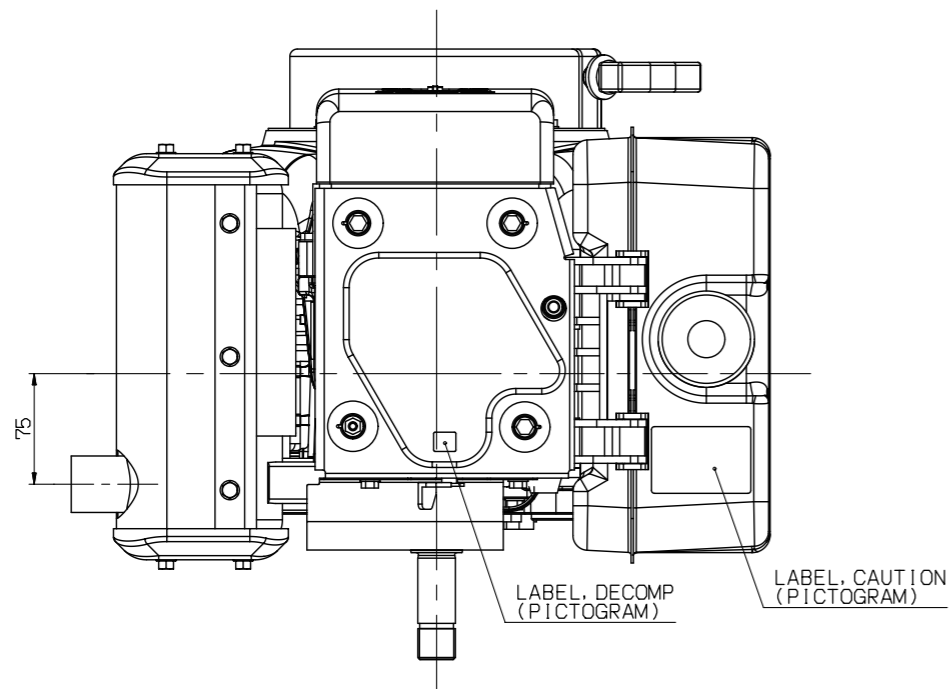
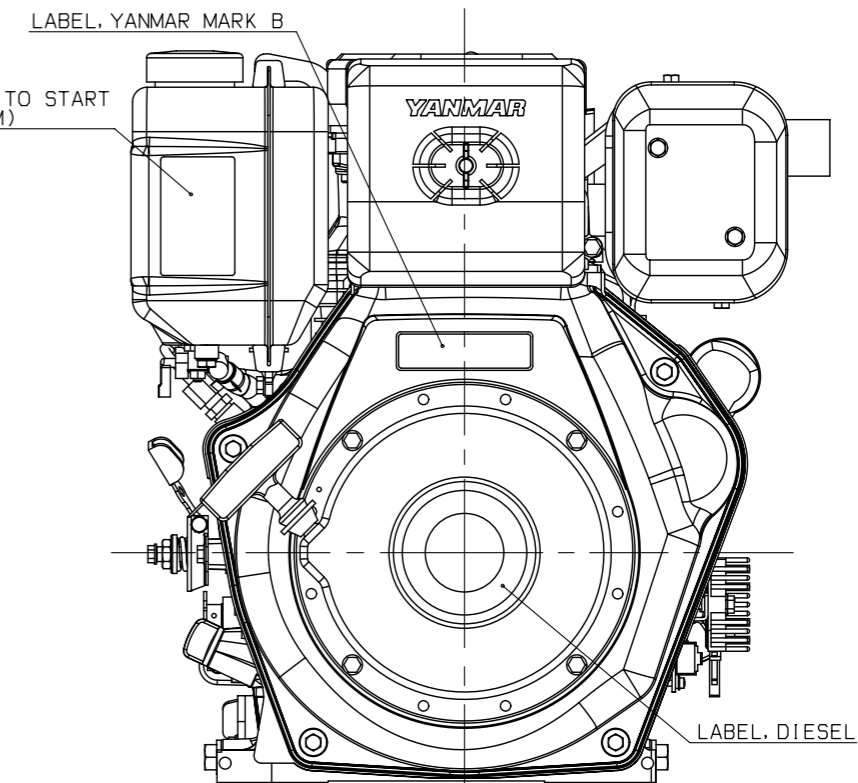
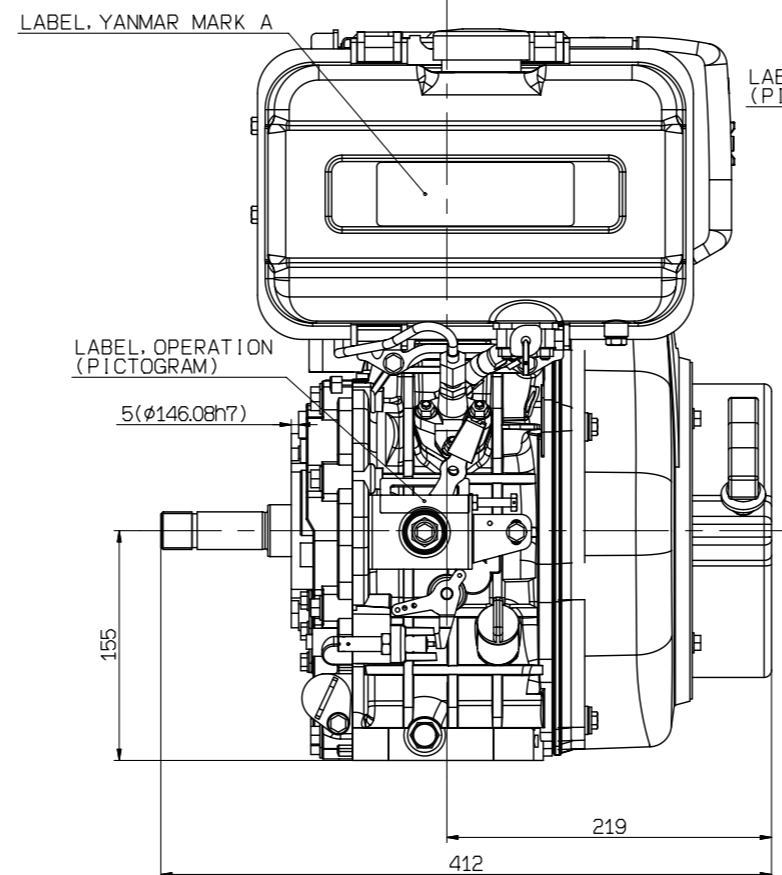
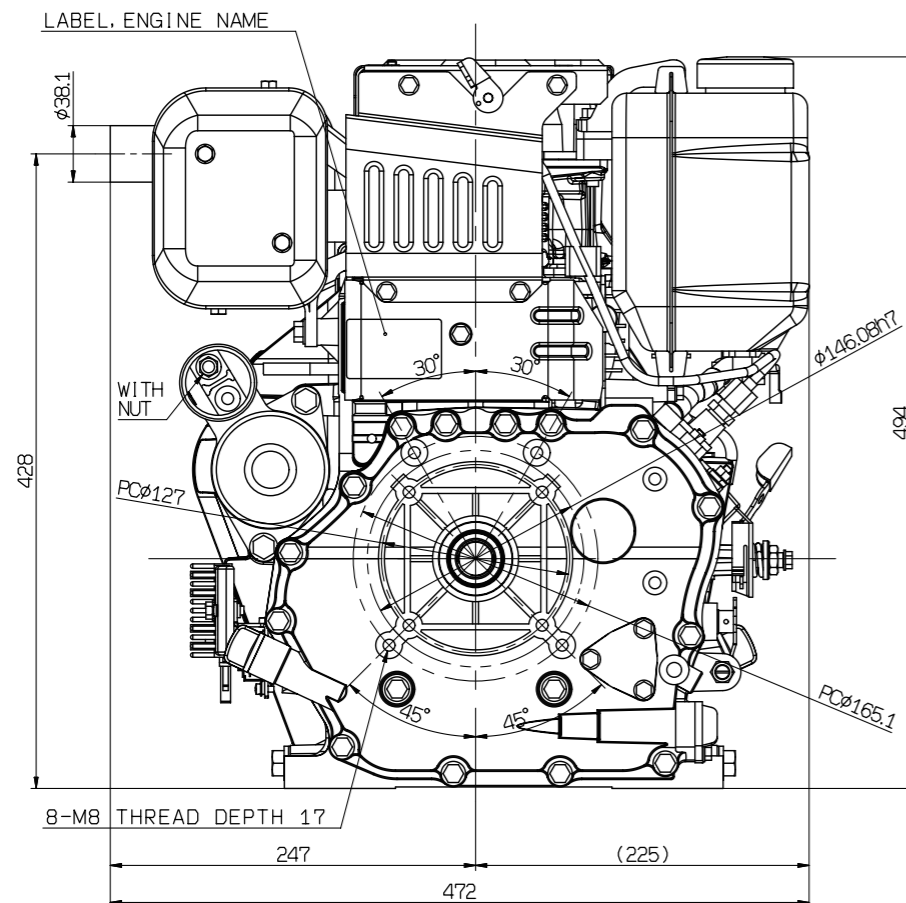

-This outline shows No.2 model as a representative
 -No.2&3 are different from No.1 at performance.
 -No.3 is different from No.2 at FIE parts and FO tank gauge.