

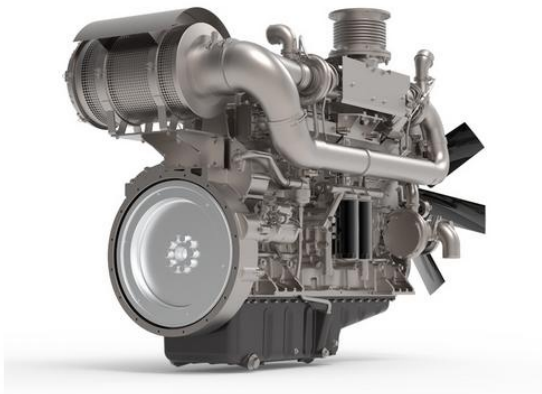

SDEC POWER

K
SERIES
POWER
GENERATION ENGINES



G-DRIVE POWERPACK

Power Generation Specification

TECHNICAL DATA SHEET

Power Output Range
728kW – 800kW

STAGE III EMISSION COMPLIANT
FOR USE IN THE FOLLOWING TERRITORIES. ASIA, MIDDLE EAST AND AFRICA.

K SERIES DIESEL ENGINE

MODELS	MAX ENGINE OUTPUT		RATED GENERATOR OUTPUT	
	Prime kW	Standby kW	Prime kVA	Standby kVA
6KTAA25-G31 (1500 rpm)	728	800	825	900
6KTAA25-G31 (1800 rpm)	-	-	-	-

Generator outputs calculated using nett engine power at 0.8 power factor, at an altitude below 1000 m.a.s.l. and 40-degree Celsius ambient temperature. Refer to the outputs and ratings tables for exact site conditions.

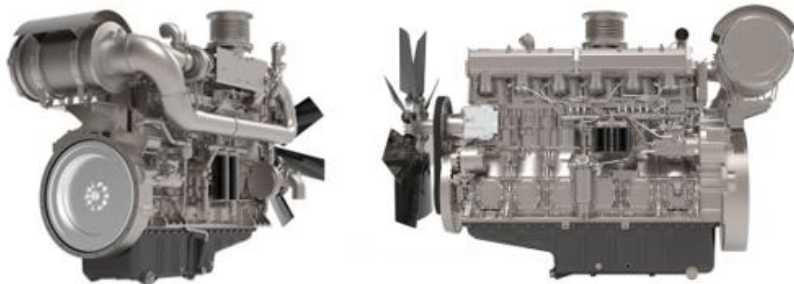

Build specification for export markets

Manufactured in the People's Republic of China

TECHNICAL ENGINE SUMMARY

SPECIFICATIONS		6KTAA25-G31	
Fuel Type	Diesel		
Method Of Cooling	Water Cooled – Set Mounted Radiator		
Number Of Cylinders	Six		
Engine Type	Inline 4 Stroke		
Bore x Stroke mm x mm	170 x 185		
Cylinder Liner Type	Dry Liner		
Total Displacement cc / L	25200 / 25.2		
Combustion Type	Direct Injection		
Aspiration - Naturally or Turbo	Turbo Charged		
Make of Turbo Charger	SDEC		
Valves Per Cylinder	4 per cylinder		
Compression Ratio	14.5:1		
Firing Order	1:5:3:6:2:4		
Swept Volume in cm ³	25195 @ 1500rpm		
Mean Piston Speed in m/min	555 @ 1500rpm		-
Cyclic Irregularity	0.015-0.025 δs		
Fuel System	Liebherr		
Steady State Speed Stability at Constant Load	G3 Class $\leq \pm 1.5$		
Flywheel & Bellhousing SAE	SAE 0-18		
Number of Teeth on Flywheel	143		
Direction of Rotation (Viewed from Flywheel)	Counterclockwise		
Moment of Inertia (Engine and Alternator) kgm ²	28.0-35.0 kgm ² depending on the alternator		
Moment of Inertia (Engine) kgm ²	12.0-18.0 kgm ²		
PROTECTIONS & SENSORS			
Method of Protection Against High Engine Temperature	D88A-005-800+A		
Method of Protection Against Low Oil Pressure	KE21103(NPT1/8;0-10)		
Method of Protection Against Low Water Level	Optional		
Method of Protection Against High Water Temperature	D88A-005-800+A		
WEIGHTS & DIMENSIONS			
Weight (Dry) / Weight (Wet) (kg)	2760 / 2890		
Length x Width x Height (Engine Only) mm	2332×1242×1659		
Length x Width x Height (Engine Only + Radiator) mm	2897×1556×1700		

RATINGS / OUTPUTS

kW (Gross kWm)	1500	1800
Max kw	800	-
kW (Nett kWm) Rated	1500	1800
Continuous kW	582	-
Prime kW	728	-
Standby kW	800	-
kWe (Nett kWe)	1500	1800
Continuous kWe	553	-
Prime kWe	692	-
Standby kWe	760	-
Based on an alternator efficiency of 95%		
kVA	1500	1800
Continuous kVA @ 0,8pf	660	-
Prime kVA @ 0,8pf	825	-
Standby kVA @ 0,8pf	900	-

These guidelines have been formulated to ensure proper application of generator drive engines in A.C. generator set installations.

STANDBY POWER RATING

Applicable for supplying emergency power for the duration of the utility power outage. No overload capability is available for this rating. Under no condition is an engine allowed to operate in parallel with the public utility at the Standby Power rating. This rating should be applied where reliable utility power is available. A Standby rated engine should be sized for a maximum of an 80% average load factor and 200 hours of operation per year. This includes less than 25 hours per year at the Standby Power rating. Standby ratings should never be applied except in true emergency power outages. Negotiated power outages contracted with a utility company are not considered an emergency.

PRIME POWER RATING

Applicable for supplying electric power in lieu of commercially purchased power. Prime Power applications must be in the form of one of the following two categories:

UNLIMITED TIME RUNNING PRIME POWER

Prime Power is available for an unlimited number of hours per year in a variable load application. Variable load should not exceed a 70% average of the Prime Power rating during any operating period of 250 hours. The total operating time at 100% Prime Power shall not exceed 500 hours per year. A 10% overload capability is available for a period of 1 hour within a 12-hour period of operation. Total operating time at the 10% overload power shall not exceed 25 hours per year.

LIMITED TIME RUNNING PRIME POWER

Limited Time Prime Power is available for a limited number of hours in a non-variable load application. It is intended for use in situations where power outages are contracted, such as in utility power curtailment. Engines may be operated in parallel to the public utility up to 750 hours per year at power levels never to exceed the Prime Power rating. The customer should be aware, however, that the life of any engine will be reduced by this constant high load operation. Any operation exceeding 750 hours per year at the Prime Power rating should use the Continuous Power rating.

CONTINUOUS POWER RATING

Applicable for supplying utility power at a constant 100% load for an unlimited number of hours per year. No overload capability is available for this rating.

NB: DC VARIABLE SPEED POWER RATING

Please consult with engineering for applications where variable speed engines are required for D.C. generator set applications.

RATINGS – DERATION CURVES

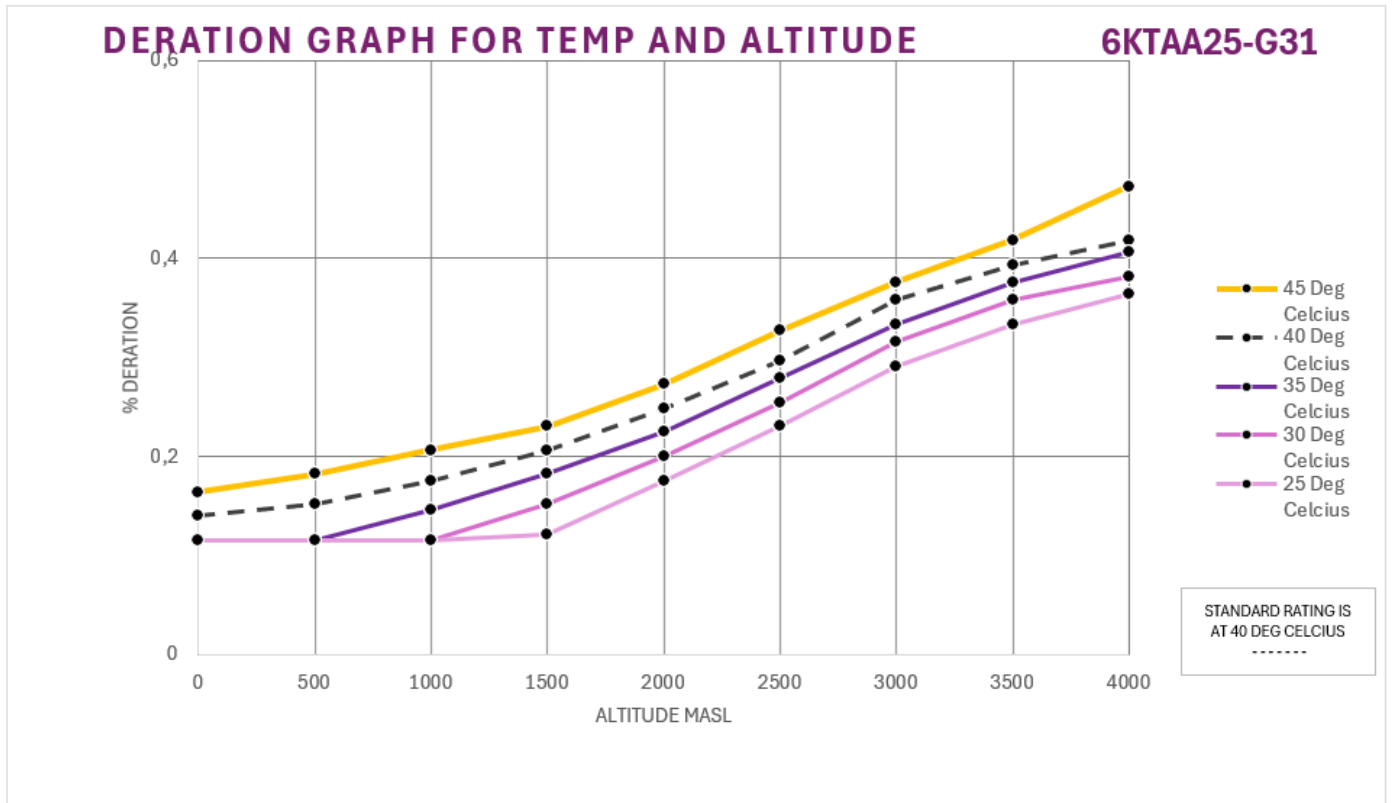

Alt.	500	1000	1500	2000	2500	3000	3500	4000
Temp								
50 Deg C	-	-	-	-	-	-	-	-
45	18%	21%	23%	27%	33%	38%	42%	47%
40	15%	18%	21%	25%	30%	36%	39%	42%
35	12%	15%	18%	22%	28%	33%	37%	41%
30	12%	12%	15%	20%	25%	32%	36%	38%
25	12%	12%	12%	18%	23%	29%	33%	36%

TEST CONDITIONS	
Air temperature. 27 °C Barometric pressure..... 100 kPa Relative humidity 30% Air inlet restriction at maximum power (nominal) 2,5 kPa Intercooler Pressure at maximum power (nominal) 2,5 kPa Exhaust back pressure at maximum pressure (nominal) ... 3,0 kPa Fuel temperature (inlet pump) 55 °C maximum	Notes: All data is based on the engine operating without alternator, optional equipment and driven components. Data shown above represents gross engine performance capabilities obtained and corrected in accordance with GB/T1147.1-2017 and Equivalent ISO 3046-1:2002 Standards for ratings (continuous, prime, standby) in accordance with GB/T2820 and Equivalent ISO 8528-1:2018

LOAD ACCEPTANCE AND GOVERNING CLASS

Initial load acceptance					
When engine reaches rated speed					
(Withing 15 seconds after engine starts to crank)					
Step Load	Prime Power Load kWm	Load kWe nett	Expected frequency deviation %	Frequency recovery time seconds	Frequency stability
25% - 75%	182 – 546	228 – 683	3-4% dip	≤ 5-8	± 0.5%
0% - 100%	0 – 728	0 – 800	5-6% dip	≤ 6-10	± 0.5%
100 – 0% load drop	728 – 0	800 – 0	4-5% overshoot	≤ 3-5	± 0.5%

VALVES AND MECHANICS

VALVE MECHANISM

Type	Overhead Valves	
Number of Valves	2 Intake & 2 Exhaust / per Cylinder	
Valve Lashes when Cold	Intake 0.35mm	
	Exhaust 0.60mm	

VALVE TIMING

	OPENING	CLOSE
Intake Valve	25 ° BTDC	57 ° ABDC
Exhaust Valve	66 ° BBDC	16 ° ATDC

ELECTRICAL SYSTEM

CHARGING ALTERNATOR

Charging Alternator Manufacturer	SDEC- S00033598
Charging Alternator	55 A x 28V
Voltage Regulator	Built In IC Regulator

STARTER MOTOR

Starter Motor Manufacturer	SDEC- S00033599
Number of Starter Motors	1
Starter Motor Power	9 Kw
Starter Motor Voltage	24 V

BATTERIES (NOT SUPPLIED / RECOMMENDED)

Battery Capacity	200 Amp Hour
Number of Battery & Type	2 x 12V Lead Acid

MODEL \ LOAD	25%	50%	75%	100%	110%
1500 rpm g/kWh	57	100	146	199	223
1500 rpm l/h	49	86	127	173	193
1800 rpm g/kWh	-	-	-	-	-
1800 rpm l/h	-	-	-	-	-

FUEL SYSTEM

Injection System

Type	E.C.U
Injection Pump	Liebherr
Injection Nozzle	Multi-Hole Type
Opening Pressure	250 kg/cm2
Injection Timing	Electric Type
Feed Pump	Mechanical
Governor	Electronic regulator
Governing Class	G3
Speed Controller	-

Fuel Filtration

Fuel Filter	Spin On Type
Fuel Filters Type	Full Flow Cartridge
Fuel Filters	3
Water Separator	Yes

Fuel

Fuel Type	Diesel
Suggested Grade / Class	50 ppm or better
Bio Diesel Compatible	Confirm the ratio with the factory before use

LUBRICATION SYSTEM

Oil Lubrication System

Lubrication Method	Fully forced pressure feed type
Oil Pump Type	Gear type driven by crankshaft

Oil Pan Capacity

High Level / Low Level (Litres)	75 / 45
---------------------------------	---------

Angularity limit

Front Down	12 °
Front Up	15 °
Side to Side	35 °

Oil Filtration

Oil Filter	Spin On Type
Oil Filters Type	Full Flow Cartridge
Oil Filters	2

Oil

Oil Type	Multigrade Oil
Suggested Grade / Class	CF-4 15W/40

ENGINE COOLING DATA AND THERMODYNAMICS

Cooling System	
Cooling Method	Fresh Water Forced Circulation
Water Capacity (Engine Only)	55 litres
Water Lid Min. Pressure	70 kPa
Water Pump	Centrifugal Type
	Belt Driven
Water Pump Capacity 1500 rpm	880 L/min
Water Pump Capacity 1800 rpm	-
Thermostat	Wax-Pellet Type
	Opening Temp. 77°C
	Full Open Temp. 90°C
Cooling Fan Type	Blower Type-Plastic
Drive Type	Mechanically Driven
Cooling Fan Construction	8 x Plastic Blades
Cooling Fan Size	1220 mm Diameter
Cooling Fan Power Consumption	24Kw
Cooling Air Flow	10.8 m ³ /s
Radiator	
Type	Set Mounted
Manufacturer	LK
Construction	Copper Core
Treatment	Tropicalised
Temperature	50 Degree
Intercooled	Yes
Antifreeze	
Fuel Type	Premix (50/50)
Compliant Grade / Class	ASTM D-3306 ASTM D-6210 SAE J814
Main Ingredient	50% Glycol or More

Heat Rejection	
Heat Rejection to Coolant	70kcal/sec (1500 rpm)
Heat Rejection to Intercooler	56kcal/sec (1500 rpm)
Max. Permissible Restrictions	3kPa
Permissible Restrictions: Intercooler	10kPa
Intake System kPa	6kPa
Max. Permissible Altitude m.a.s.l.	2000m
Exhaust System	
Exhaust Gas flow	140m ³ /min (1500 rpm)
Exhaust Gas Temperature Max °C	600°C
Exhaust Outlet Size (Internal) mm	Ø200
Exhaust Outlet Flange Size mm	Ø295
Exhaust Flange & Bellow Supplied	Yes
Back Pressure for Total System at Standby Power	10 Kpa
Exhaust Smoke (FSN)	≤1.0
Turbo Charger	
Manufacturer	SDEC
Boost Pressure Ratio	14.5:1
Water Jacket Cooling Data (Optional)	
Coolant Flow - litres/min	27-33 L/min
Coolant Exit Temperature (max) °C	80 °C
Coolant Inlet Temperature (min) °C	-40 °C
Coolant Inlet Temperature (max) °C	+60 ° to 70 °C
Suggested Pump Rating kW	2.25 KW
Colour of the engine	
RAL(Colour)	RAL 9006 (White/Silver Aluminium)

SIDE VIEW - RHS

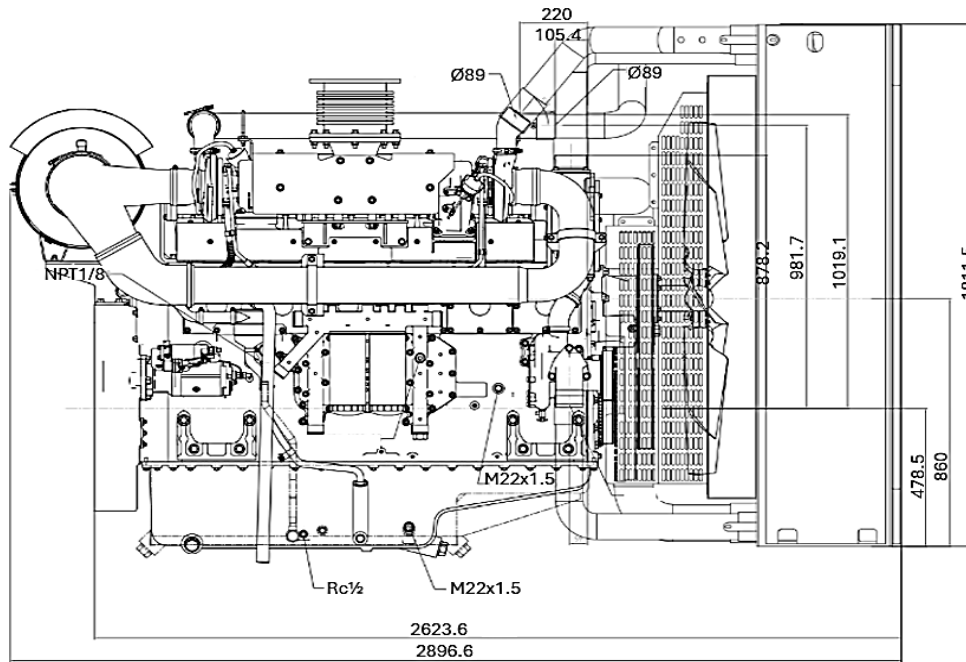

SIDE VIEW - LHS

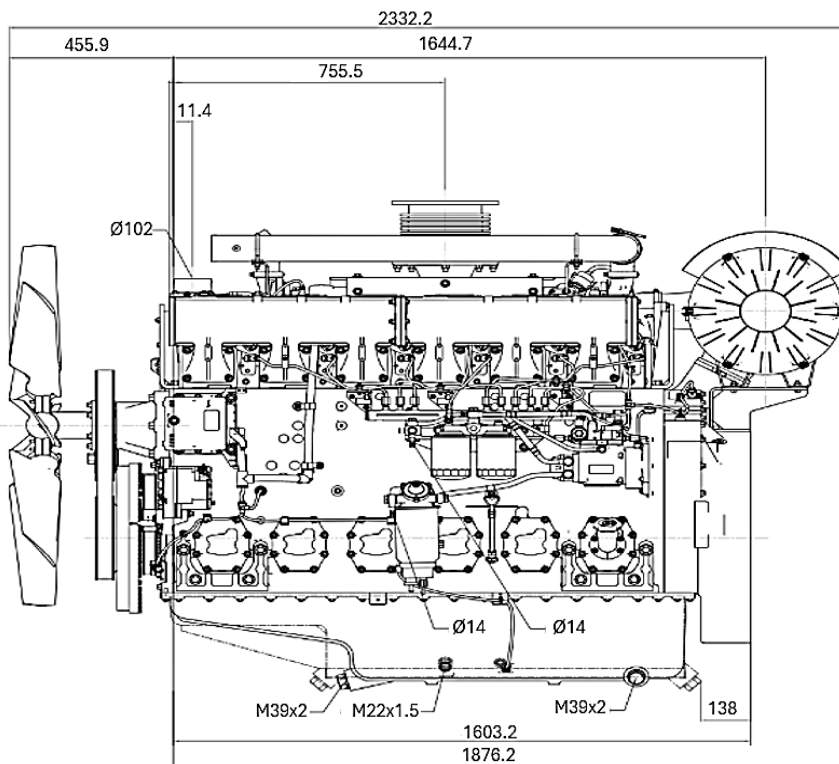

FRONT VIEW- FAN

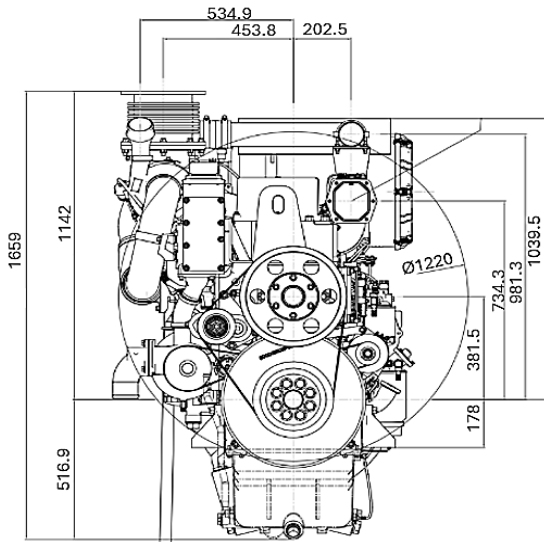

TOP VIEW - AERIAL

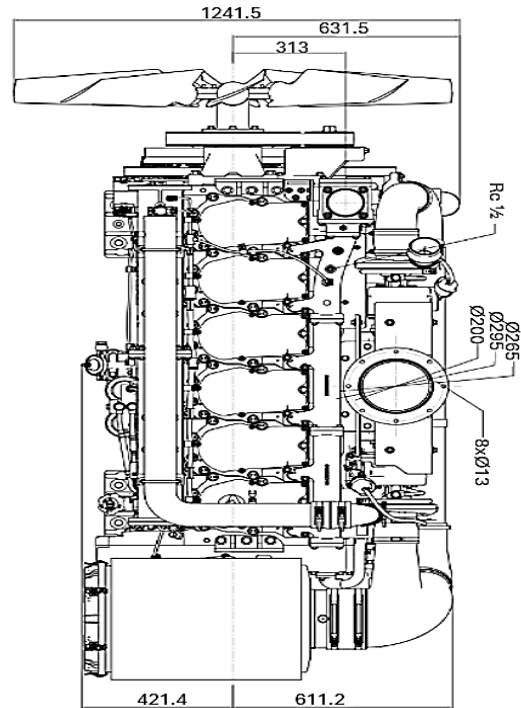

REAR VIEW - FLYWHEEL

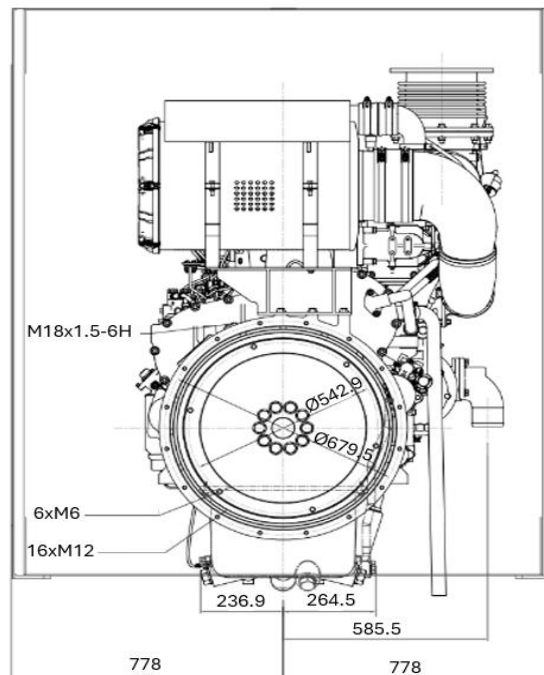

SERVICE AND CRITICAL PARTS

SERVICE HOURS		50	100	250 Monthly	1000 Annually
SERVICE PART	PART NO.				
Air Filter (Inner)	4050137	-	-	Yes	Yes
Air Filter (Outer)	-	-	-	-	-
Fuel Filter (Outer)	4050141+S00031285	-	-	Yes	Yes
Fuel / Water Separator	-	-	-	-	-
Oil Filter	4050136	-	-	Yes	Yes
Fan Belt	S00033425+S00034595	Check for wear or damage	Check for wear or damage	Check for wear or damage	Yes
Timing Belt	-	-	-	-	-
Oil	API CH4 15W/40	Check Level	Check Level	Yes	Yes
Anti-Freeze	50/50 (Premix)	Check Level	Check Level	Check Level	Check Level
CRITICAL PARTS					
SERVICE PART	PART NO.				
Charging Alternator	S00033598				
Starter Motor	S00033599				
Valve Cover Gasket	S00034296				
Radiator	S1972				
Speed Controller / ECU	ECU				
Turbocharger	S00052426+S00052427				
Lift Pump	Provide engine build no				
Fuel Pump	S00035921				
Oil Pump	S00032623				

