



SDEC POWER

**H**  
SERIES  
POWER  
GENERATION ENGINES



## G-DRIVE POWERPACK

Power Generation Specification

### TECHNICAL DATA SHEET

**Power Output Range**  
168kW – 198kW

STAGE II EMISSION COMPLIANT  
FOR USE IN THE FOLLOWING TERRITORIES. ASIA, MIDDLE EAST AND AFRICA.

## H SERIES DIESEL ENGINE

MODELS	MAX ENGINE OUTPUT		RATED GENERATOR OUTPUT	
	Prime kW	Standby kW	Prime kVA	Standby kVA
<b>6HTAA6.5-G23 (1500 rpm)</b>	<b>168</b>	<b>185</b>	<b>188</b>	<b>206</b>
<b>6HTAA6.5-G23 (1800 rpm)</b>	<b>180</b>	<b>198</b>	<b>200</b>	<b>220</b>

Generator outputs calculated using nett engine power at 0.8 power factor, at an altitude below 1000 m.a.s.l. and 40-degree Celsius ambient temperature.  
Refer to the outputs and ratings tables for exact site conditions.



**Build specification for export markets**

Manufactured in the People's Republic of China

SPECIFICATIONS	6HTAA6.5-G23	
Fuel Type	Diesel	
Method Of Cooling	Water Cooled – Set Mounted Radiator	
Number Of Cylinders	6	
Engine Type	Inline 4 Stroke	
Bore x Stroke mm x mm	105 x 124	
Cylinder Liner Type	Dry Liner	
Total Displacement cc / L	6500 / 6.5	
Combustion Type	Direct Injection	
Aspiration - Naturally or Turbo	Turbo Charged	
Make of Turbo Charger	SDEC	
Valves Per Cylinder	4 per cylinder	
Compression Ratio	16:1	
Firing Order	1:5:3:6:2:4	
Swept Volume in cm <sup>3</sup>	6442 @ 1500rpm	
Mean Piston Speed in m/min	372 @ 1500rpm	446 @ 1800rpm
Cyclic Irregularity	0.035-0.045 δs	
Fuel System	Beiyou Inline Pump	
Steady State Speed Stability at Constant Load	G2 Class ≤ ± 1.5	
Flywheel & Bellhousing SAE	SAE 3-11.5	
Number of Teeth on Flywheel	127	
Direction of Rotation (Viewed from Flywheel)	Counterclockwise	
Moment of Inertia (Engine and Alternator) kgm <sup>2</sup>	8.0-10.0 kgm <sup>2</sup> depending on the alternator	
Moment of Inertia (Engine) kgm <sup>2</sup>	2.5-3.5 kgm <sup>2</sup>	
PROTECTIONS & SENSORS		
Method of Protection Against High Engine Temperature	KE00105(3/8-18NPT)	
Method of Protection Against Low Oil Pressure	KE21103(NPT1/8;0-10)	
Method of Protection Against Low Water Level	JKE00120 1/2"-G	
Method of Protection Against High Water Temperature	KE00105(3/8-18NPT)	
WEIGHTS & DIMENSIONS		
Weight (Dry) / Weight (Wet) (kg)	600 / 627	
Length x Width x Height (Engine Only) mm	1330 × 789 × 1079	
Length x Width x Height (Engine Only + Radiator) mm	1461 × 805 × 1079	

<b>kW (Gross kWm)</b>	<b>1500</b>	<b>1800</b>
Max kw	185	198
<b>kW (Nett kWm) Rated</b>	<b>1500</b>	<b>1800</b>
Continuous kW	134	144
Prime kW	168	180
Standby kW	185	198
<b>kWe (Nett kWe)</b>	<b>1500</b>	<b>1800</b>
Continuous kWe	128	137
Prime kWe	160	171
Standby kWe	176	188
Based on an alternator efficiency of 95%		
<b>kVA</b>	<b>1500</b>	<b>1800</b>
Continuous kVA @ 0,8pf	150	160
Prime kVA @ 0,8pf	188	200
Standby kVA @ 0,8pf	206	220

These guidelines have been formulated to ensure proper application of generator drive engines in A.C. generator set installations.

#### STANDBY POWER RATING

Applicable for supplying emergency power for the duration of the utility power outage. No overload capability is available for this rating. Under no condition is an engine allowed to operate in parallel with the public utility at the Standby Power rating. This rating should be applied where reliable utility power is available. A Standby rated engine should be sized for a maximum of an 80% average load factor and 200 hours of operation per year. This includes less than 25 hours per year at the Standby Power rating. Standby ratings should never be applied except in true emergency power outages. Negotiated power outages contracted with a utility company are not considered an emergency.

#### PRIME POWER RATING

Applicable for supplying electric power in lieu of commercially purchased power. Prime Power applications must be in the form of one of the following two categories:

#### UNLIMITED TIME RUNNING PRIME POWER

Prime Power is available for an unlimited number of hours per year in a variable load application. Variable load should not exceed a 70% average of the Prime Power rating during any operating period of 250 hours. The total operating time at 100% Prime Power shall not exceed 500 hours per year. A 10% overload capability is available for a period of 1 hour within a 12-hour period of operation. Total operating time at the 10% overload power shall not exceed 25 hours per year.

#### LIMITED TIME RUNNING PRIME POWER

Limited Time Prime Power is available for a limited number of hours in a non-variable load application. It is intended for use in situations where power outages are contracted, such as in utility power curtailment. Engines may be operated in parallel to the public utility up to 750 hours per year at power levels never to exceed the Prime Power rating. The customer should be aware, however, that the life of any engine will be reduced by this constant high load operation. Any operation exceeding 750 hours per year at the Prime Power rating should use the Continuous Power rating.

#### CONTINUOUS POWER RATING

Applicable for supplying utility power at a constant 100% load for an unlimited number of hours per year. No overload capability is available for this rating.

#### NB: DC VARIABLE SPEED POWER RATING

Please consult with engineering for applications where variable speed engines are required for D.C. generator set applications.

**RATINGS – DERATION CURVES**

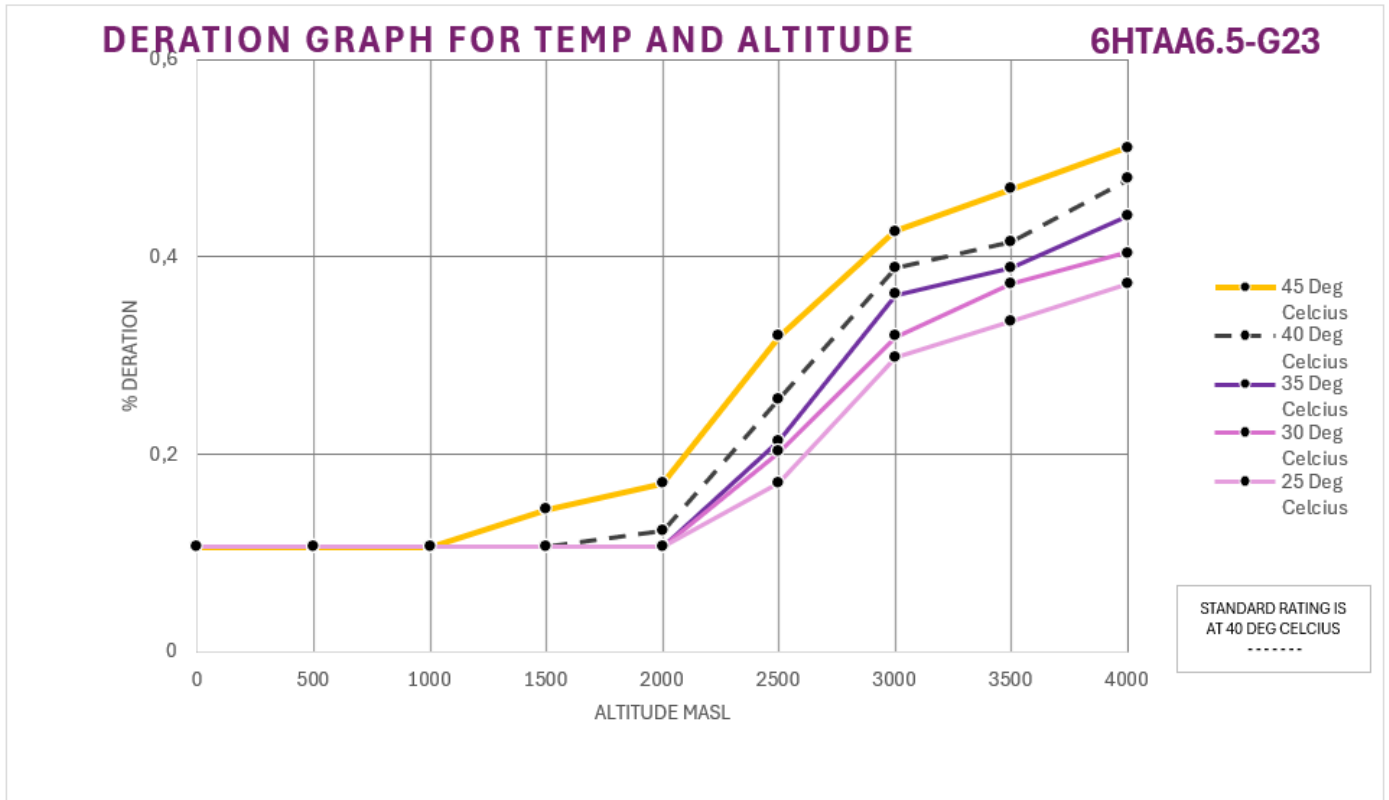

Alt.	500	1000	1500	2000	2500	3000	3500	4000
Temp 50 Deg C	-	-	-	-	-	-	-	-
45	11%	11%	14%	17%	32%	43%	47%	51%
40	11%	11%	11%	12%	26%	39%	41%	48%
35	11%	11%	11%	11%	21%	36%	39%	44%
30	11%	11%	11%	11%	20%	32%	37%	40%
25	11%	11%	11%	11%	17%	30%	34%	37%

**TEST CONDITIONS**

Air temperature..... 27 °C  
 Barometric pressure..... 100 kPa  
 Relative humidity ..... 30%  
 Air inlet restriction at maximum power (nominal) ..... 2,5 kPa  
 Intercooler Pressure at maximum power (nominal) ..... 2,5 kPa  
 Exhaust back pressure at maximum pressure (nominal) ... 3,0 kPa  
 Fuel temperature (inlet pump) ..... 55 °C maximum

**Notes:**

All data is based on the engine operating without, alternator, optional equipment and driven components. Data shown above represents gross engine performance capabilities obtained and corrected in accordance with GB/T1147.1-2017 and Equivalent ISO 3046-1:2002  
 Standards for ratings (continuous, prime, standby) in accordance with GB/T2820 and Equivalent ISO 8528-1:2018

## LOAD ACCEPTANCE AND GOVERNING CLASS

Initial load acceptance					
When engine reaches rated speed					
(Withing 15 seconds after engine starts to crank)					
Step Load	Prime Power Load kWm	Load kWe nett	Expected frequency deviation %	Frequency recovery time seconds	Frequency stability
25% - 75%	42 – 126	53 – 158	3-5% dip	≤ 5-8	± 0.5%
0% - 100%	0 – 168	0 – 185	5-8% dip	≤ 8-10	± 0.5%
100 – 0% load drop	168 – 0	185 – 0	5-7% overshoot	≤ 3-6	± 0.5%

## VALVES AND MECHANICS

### VALVE MECHANISM

Type	Overhead Valves	
Number of Valves	2 Intake & 2 Exhaust / per Cylinder	
Valve Lashes when Cold	Intake 0.25mm	
	Exhaust 0.50mm	

### VALVE TIMING

	OPENING	CLOSE
Intake Valve	20.9 ° BTDC	44.9 ° ABDC
Exhaust Valve	51.7 ° BBDC	11.7 ° ATDC

## ELECTRICAL SYSTEM

### CHARGING ALTERNATOR

Charging Alternator Manufacturer	SDEC- S00012977
Charging Alternator	55 A x 28V
Voltage Regulator	Built In IC Regulator

### STARTER MOTOR

Starter Motor Manufacturer	SDEC- S00025086
Number of Starter Motors	1
Starter Motor Power	6 Kw
Starter Motor Voltage	24 V

### BATTERIES (NOT SUPPLIED / RECOMMENDED)

Battery Capacity	150 Amp Hour
Number of Battery & Type	2 x 12V Lead Acid

## FUEL CONSUMPTION

MODEL	LOAD				
	25%	50%	75%	100%	110%
1500 rpm g/kWh	57	103	148	199	221
1500 rpm l/h	11	21	30	40	44
1800 rpm g/kWh	59	104	149	203	226
1800 rpm l/h	13	22	32	43	48

## FUEL SYSTEM

### Injection System

Type	Electronic
Injection Pump	Longkou in-line "AD" type
Injection Nozzle	Multi-Hole Type
Opening Pressure	250 kg/cm <sup>2</sup>
Injection Timing	10.5°BTDC
Feed Pump	Mechanical
Governor	Electronic Regulator
Governing Class	G2
Speed Controller	Fortrust C2004

### Fuel Filtration

Fuel Filter	Spin On Type
Fuel Filters Type	Full Flow Cartridge
Fuel Filters	1 Primary
Water Separator	Optional

### Fuel

Fuel Type	Diesel
Suggested Grade / Class	50 ppm or better
Bio Diesel Compatible	Confirm the ratio with the factory before use

## LUBRICATION SYSTEM

### Oil Lubrication System

Lubrication Method	Fully forced pressure feed type
Oil Pump Type	Gear type driven by crankshaft

### Oil Pan Capacity

High Level / Low Level (Litres)	17.5 / 15
---------------------------------	-----------

### Angularity limit

Front Down	25 °
Front Up	35 °
Side to Side	35 °

### Oil Filtration

Oil Filter	Spin On Type
Oil Filters Type	Full Flow Cartridge
Oil Filters	1 Primary

### Oil

Oil Type	Multigrade Oil
Suggested Grade / Class	CH 15W/40

Cooling System	
Cooling Method	Fresh Water Forced Circulation
Water Capacity (Engine Only)	9.6 litres
Water Lid Min. Pressure	70 kPa
Water Pump	Centrifugal Type
	Belt Driven
Water Pump Capacity 1500rpm	129 L/min
Water Pump Capacity 1800 rpm	155L/min
Thermostat	Wax-Pellet Type
	Opening Temp. 82°C
	Full Open Temp. 95°C
Cooling Fan Type	Blower Type-Plastic
Drive Type	Mechanically Driven
Cooling Fan Construction	10 x Plastic Blades
Cooling Fan Size	660 mm Diameter
Cooling Fan Power Consumption	6kW
Cooling Air Flow	4.5 m <sup>3</sup> /s
Radiator	
Type	Set Mounted
Manufacturer	LK
Construction	Copper Core
Treatment	Tropicalised
Temperature	50 Degree
Intercooled	Yes
Antifreeze	
Fuel Type	Premix (50/50)
Compliant Grade / Class	ASTM D-3306 ASTM D-6210 SAE J814
Main Ingredient	50% Glycol or More

Heat Rejection	
Heat Rejection to Coolant	17kcal/sec (1500 rpm)
	18kcal/sec (1800 rpm)
Heat Rejection to Intercooler	11kcal/sec (1500 rpm)
	11kcal/sec (1800 rpm)
Max. Permissible Restrictions	3kPa
Permissible Restrictions: Intercooler	8kPa
Intake System kPa	6kPa max
Max. Permissible Altitude m.a.s.l.	2000m
Exhaust System	
Exhaust Gas flow	28m <sup>3</sup> /min (1500 rpm)
	35m <sup>3</sup> /min (1800 rpm)
Exhaust Gas Temperature Max °C	600°C
Exhaust Outlet Size (Internal) mm	Ø84
Exhaust Outlet Flange Size mm	Ø150
Exhaust Flange & Bellow Supplied	No
Back Pressure for Total System at Standby Power	6 kPa max
Exhaust Smoke (FSN)	≤1.5
Turbo Charger	
Manufacturer	SDEC
Boost pressure ratio	16:1
Water Jacket Cooling Data (Optional)	
Coolant Flow - litres/min	5l/min
Coolant Exit Temperature (max) °C	70-85 °C
Coolant Inlet Temperature (min) °C	-40 °C
Coolant Inlet Temperature (max) °C	+60 °C to +70 °C
Suggested Pump Rating kW	1 kW
Colour of the engine	
RAL(Colour)	RAL 9006 (White/Silver Aluminium)

SIDE VIEW - RHS

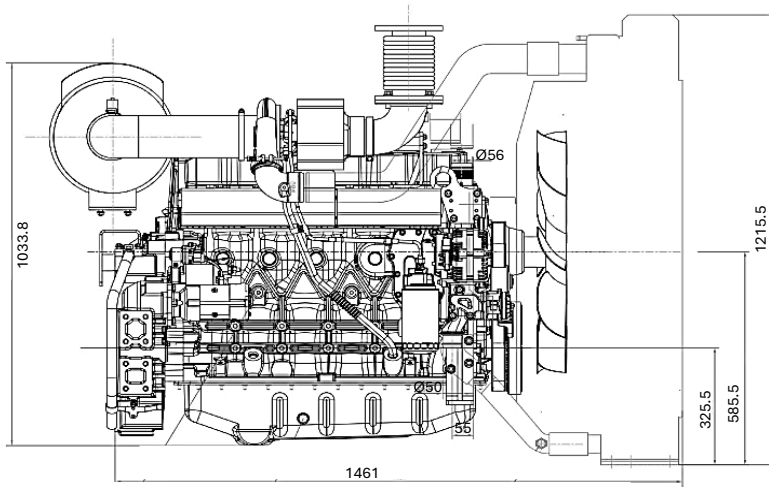

SIDE VIEW - LHS

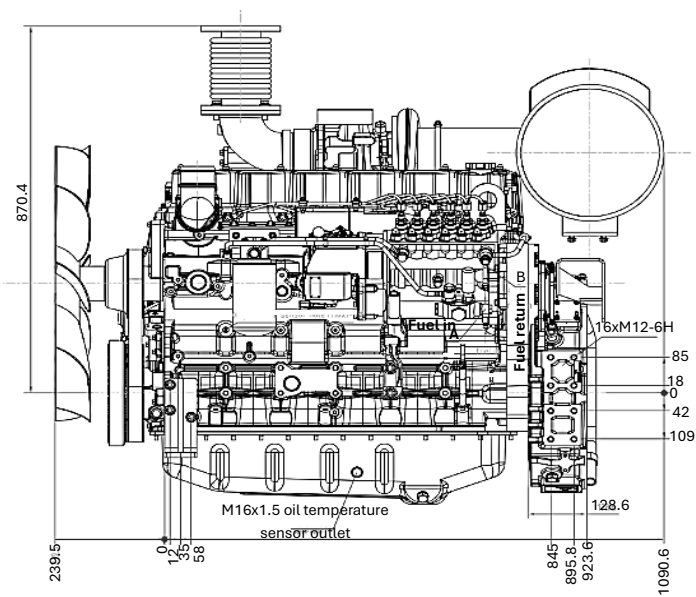

**FRONT VIEW- FAN**

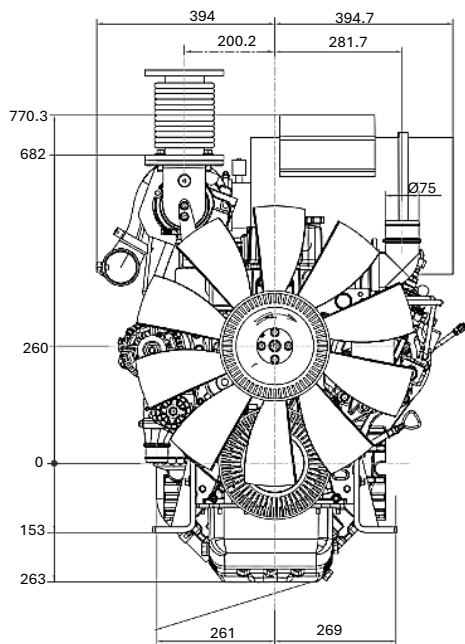

**TOP VIEW - AERIAL**

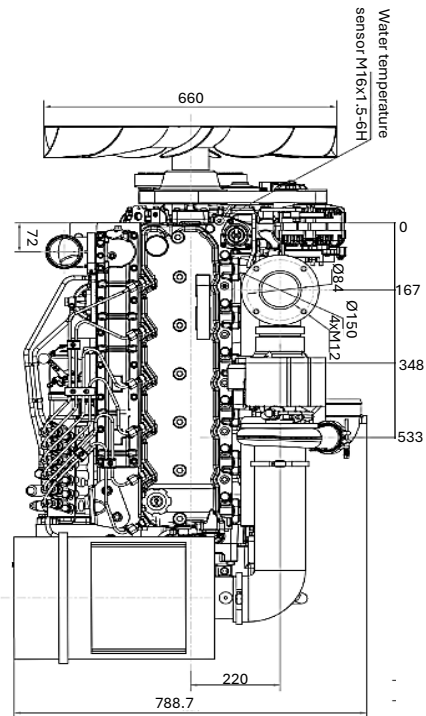

**REAR VIEW - FLYWHEEL**

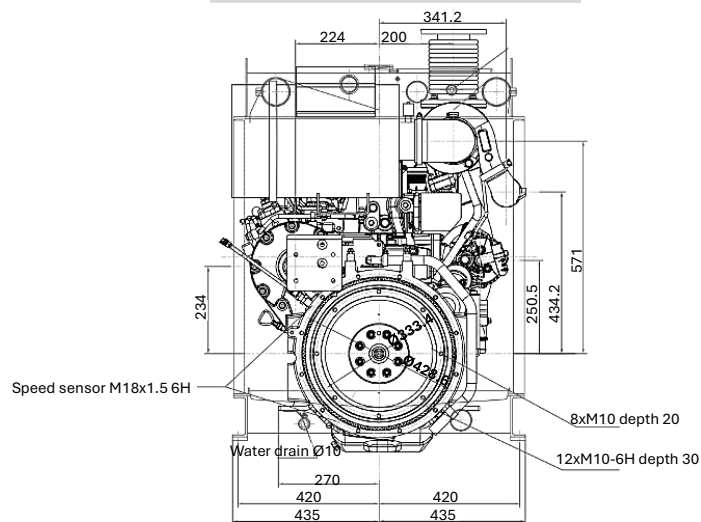

## SERVICE AND CRITICAL PARTS

SERVICE HOURS		50	100	250 Monthly	1000 Annually
SERVICE PART	PART NO.				
Air Filter (Inner)	4050130	-	-	Yes	Yes
Air Filter (Outer)	-	-	-	-	-
Fuel Filter (Outer)	2040102	-	-	Yes	Yes
Fuel / Water Separator	-	-	-	-	-
Oil Filter	2040107	-	-	Yes	Yes
Fan Belt	S00017994	Check for wear or damage	Check for wear or damage	Check for wear or damage	Yes
Timing Belt	-	-	-	-	-
Oil	CH 15W/40	Check Level	Check Level	Yes	Yes
Anti-Freeze	50/50 (Premix)	Check Level	Check Level	Check Level	Check Level
CRITICAL PARTS					
SERVICE PART	PART NO.				
Charging Alternator	S00012977				
Starter Motor	S00025086				
Valve Cover Gasket	S00004754				
Radiator	S1265				
Speed Controller / ECU	ESG2002A800C-W				
Turbocharger	S00013410				
Lift Pump	Provide engine build no				
Fuel Pump	S00010459				
Oil Pump	S00003915				

