



YANMAR CO.,LTD.

G3-29937-0070

4TNV98T-GGEA

for Generator

SPECIFICATIONS & DRAWINGS FOR MASS PRODUCTION

29.Feb.2008

YANMAR CO.,LTD.

ENGINE SPECIFICATIONS

G3-29937-0070

No	Model name	4TNV98T-GGEA		Remarks	
1	Type	4 cycle, Inline, Water-cooled Diesel			
2	No. of cylinders-Bore×stroke	mm	4-φ98×110		
3	Combustion system	Direct Injection			
4	Compression ratio	18.1			
5	Displacement	litter	3.319		
6	Rated output	kW(PS)	41.4(56.3)/50.1(68.1)		
		min ⁻¹	1500/1800		
7	Continuous rating	kW(PS)	37.7(51.3)/45.3(61.6)		
		min ⁻¹	1500/1800		
8	Max. torque	N·m	~		
		min ⁻¹	(+)		
9	Specific fuel consumption	g/kW-h(g/PS-h)	222(164)	at rated output	
10	Ambient condition	25°C、750mmHg、30%			
11	Engine speed at no load	Max.	min ⁻¹	1925	+25/-25
		Min.	min ⁻¹	1500	+25/-25
12	Governorability	Governor type	centrifugal-all speed governor		
		Temporary	%	max.10	load 100% ↓ 0%
		Permanent	%	max.5	
		Recovery time	sec	max.5	
		Stability	min ⁻¹	max.15	
Gradients	Longitudinal	deg	30(25)	intermitted	
		Lateral	deg	30(25)	() : continuous
14	Firing order	1-3-4-2-1		order from F.W.	
15	Direction of rotation	counterclockwise		viewed from F.W.	
16	Engine dry weight	kg	approx.258		
17	Fuel injection timing	deg	FIT10.5(+1/-1)	FIT b.T.D.C	
18	Fuel system	Fuel type	Diesel oil		
		Fuel injection pump	Distributortype(YPD-MP4),Yanmar made		
		Fuel injection nozzle	hole type		
		Fuel filter	paper element		
19	Lubrication system	System	forced feed		
		Oil grade	API class CD, SAE grade 10W30		
		Oil pump	trochoid pump		
		Oil filter	paper element		
		Oil capacity	liter	10.5	max.
			liter	4.5	effective.
		Oil pressure	kgf/cm ²	3.5	at rated output
kgf/cm ²	1		at low idle		
20	Cooling system	Heat exchanger	none		
		Pressure cap	kgf/cm ²	0.9	
		Fan	6-φ430		
		Coolant capacity	liter	4.2	

4TNV98T-GGEA

ENGINE SPECIFICATIONS

G3-29937-0070

No	Model name	4TNV98T-GGEA	Remarks
21	Air cleaner	7inchi double Element Type	
22	Breather system	open	
23	Muffler	none	
24	Starting system	Starter	12V-2.3kW
		Battery	95D31
		Starting aid	air heater 500W
25	Generator	12V-40A	
26	Engine color	Silver	
27	Applied regulation		

< Career >

	W.No.	4TNV98T-GGEA
--	-------	--------------

4TNV98T-GGEA

SCOPE OF SUPPLY

G3-29937-0070

No	ENGEN MODEL	4TNV98T-GGEA	Parts number	Remarks
FUEL SYSTEM				
1	Fuel Injection Pump	installed	729937-51390	
2	Fuel Injection Nozzle	installed	729906-53100	Mark"VBS"
3	Fuel Transfer Pump	provided	119225-52102	As loose parts
4	Fuel Filter	installed	123907-55801	5 μ , 5000cm ²
5	Fuel Filter Bracket	installed	129004-55612	
6	Fuel Injection Line	installed	129908-59800	
7	Fuel Line(Filter to Pump)	installed	129457-59010	L=350
8	Fuel Pipe (Pump to Filter)	installed	129981-59010	L=460
9	Water Separator	provided	119802-55700	As loose parts
10	Throttle Lever	installed	129937-61440	
LUB,OIL SYSTEM				
11	Oil Pan	installed	129982-01710	DEEP
12	Oil filler Extension pipe	installed	124160-01751	
13	Breather Pipe	installed	119006-03090 129908-03099	
14	Switch ,lub .oil pressure	installed	114250-39450	0.5kg/cm2 (CA104)
15	LO pressure sender	installed	119773-91501	
16	Dipstick	installed	129953-34830	
17	Guide ,dipstick	installed	121520-34810	
18	Oil filter	installed	129150-35160	
19	Oil Cooler	not provided	none	
COOLING SYSTEM				
20	Radiator	provided	129940-44500	As loose parts
21	Rubber Isolaters	provided	129255-44660	As loose parts
22	Pipe A,radiator	provided	129981-49050	As loose parts
23	Pipe B,radiator	provided	129981-49062	As loose parts
24	Sub tank(radiator)	provided	120445-44530	As loose parts
25	Water Pump	installed	129907-42000	LOW
26	Cooling Fan	installed	129916-44740	Mark"UT" ϕ 430push
27	Spacer ,fan	installed	119130-44760	t=18mm
28	Guide ,fan	provided	119907-44560	As loose parts
29	Pully ,fan	installed	129900-42461	D=110mm
30	V-Belt	installed	25132-004100	A41inch
31	Switch, water temp.	installed	121250-44901	110°C
32	Sender, water temp.	installed	124250-49351	
33	Thermostat	installed	121850-49810	71deg
34	Thermostat Cover	installed	129916-49530	
35	Water Drain Fitting	installed	171056-49120	PLUG
36	3-Way Plug ,cooling water	not provided	none	
ELECTRIC SYSTEM				
37	Starter	installed	129900-77010	12V-2.3kW(HITACHI)
38	Alternator	installed	129423-77200	12V-40A(DENSO)
39	Relay ,solenoid	provided	119650-77910	As loose parts
40	Timer ,solenoid	provided	129211-77920	As loose parts
41	Engine Shut Off	installed	119653-77950	
42	Starting Aid	installed	119005-77051	12V-400W
43	Diode ,solenoid relay	provided	119643-66900	As loose parts
44	Timer, air heater (glow)	provided	128300-77920	As loose parts
45	Relay, air heater (glow)	not provided	none	
46	Current Limiter	not provided	none	
47	Safety relay, starter	not provided	none	

PTO SYSTEM				
48	Flywheel Housing or Back plate	installed	129915-01610	
49	Flywheel	installed	129920-21580	SAE#3
50	Bearing ,retainer	not provided	none	
51	Pully ,crankshaft	installed	129907-21660	D=130mm
52	Gear case	installed	129907-01800	
53	Hydraulic Pump	not provided	none	
54	Device ,hydraulic pump	not provided	none	
INTAKE/EXHAUST SYSTEM				
55	Air Cleaner	installed	129908-12500	
56	Bracket ,air cleaner	installed	129944-12620	
57	Manifold ,intake	installed	129944-12110	
58	Joint	installed	129935-18350	DUCT
59	Muffler	not provided	none	
60	Gasket ,muffler	provided	123901-18080	As loose parts
61	Manifold ,exhaust	installed	129935-13100	
62	Bend ,exhaust	not provided	none	
63	Turbine	installed	129935-18010	RHF5
GAUGE				
64	Drive Unit ,tachometer	not provided	none	
65	Cable ,tachometer	not provided	none	
66	Tachometer	not provided	none	
67	Key Switch	not provided	none	
68	Cover ,terminals	not provided	none	
69	Pilot lamp	not provided	none	
70	Guage ,oil/water temp	not provided	none	
71	Guage ,oil pressure	not provided	none	
OTHERS				
72	Filter Wrench ,lub .oil	not provided	none	
73	Filter Wrench ,fuel .oil	not provided	none	

MARK	COLOR
B	Black
W	White
R	Red
L	Blue
G	Green
Y	Yellow
Br	Brown
Lg	Light Green
Sb	Sky blue
O	Orange
P	Pink
Gr	Gray
R/W	Red/White

	B	R1	R2	ACC	C	BR
PRE-HEATING	○	○	○	○	○	○
OFF	○	○	○	○	○	○
ON	○	○	○	○	○	○
START	○	○	○	○	○	○

KEY SW. DIAGRAM

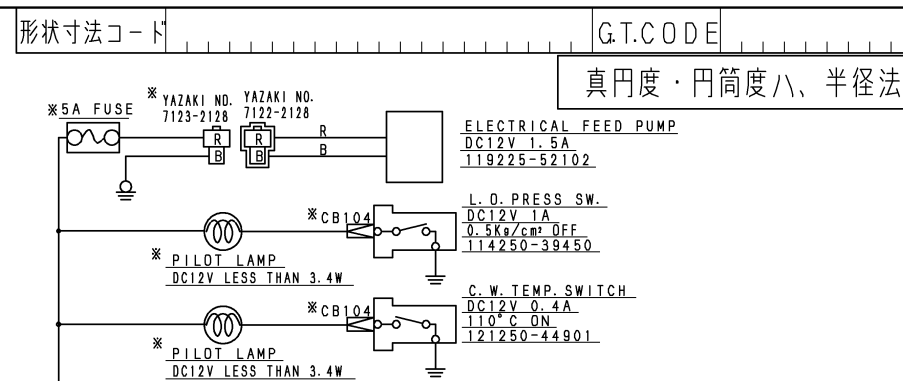
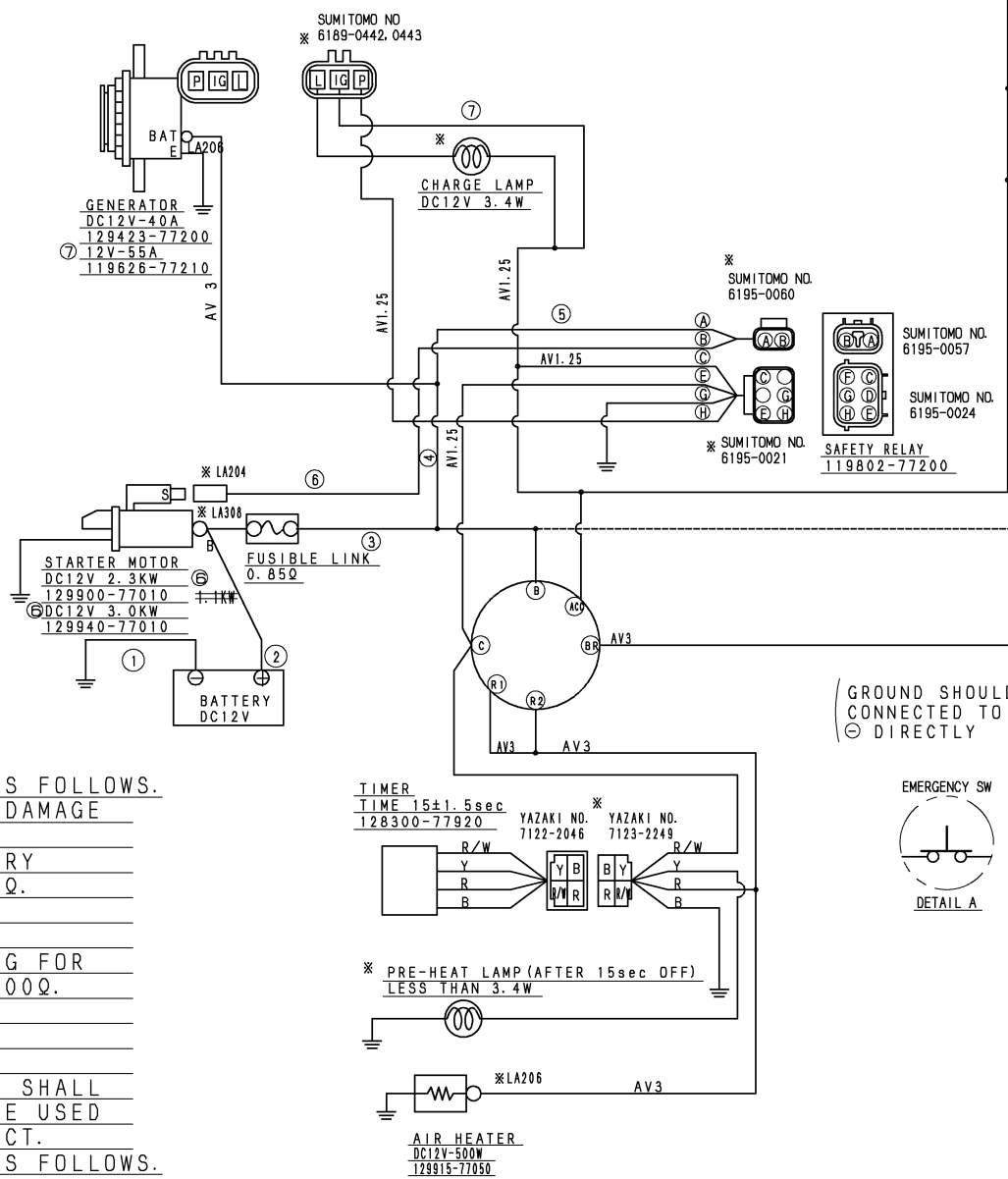

NOTES

1. WIRING OF STARTER MUST BE OBSERVED AS FOLLOWS. OTHERWISE IT CAUSES MISS STARTING OR DAMAGE OF STARTERMOTOR.
 - 1-1. TOTAL ELECTRIC RESISTANCE OF BATTERY CABLE (①+②) SHOULD BE LESS THAN 2/1000Ω. REFERENCE: AV15: ≤1.4m, AV20: ≤2.2m, AV30: ≤3.8m, AV40: ≤4.6m
 - 1-2. TOTAL ELECTRIC RESISTANCE OF WIRING FOR STARTER (③~⑥) SHOULD BE LESS THAN 5/100Ω. REFERENCE OF TERMINAL RESISTANCE: 15/1000Ω PER COUPLER, 0Ω PER SCREW SETTING
 - 1-3. BATTERY EARTH CABLE (①) CONNECTION SHALL BE ENSURED. PAINTED SURFACE MAY NOT BE USED (FOR EARTHING) AVOIDING THE MISS CONTACT.
2. BATTERY TREATMENT MUST BE OBSERVED AS FOLLOWS. OTHERWISE IT MAY CAUSE BURNING OF ELECTRIC EQUIPMENTS OR COMPONENTS. ALTERNATOR (DIODES) BURNING CAUSED BY BATTERY CABLE CONNECTION REVERSELY IS NOT WARRANTED.
 - 2-1. BATTERY SHOULD BE FIXED BY FITTING. (NOT TO MOVE)
 - 2-2. BATTERY CABLE LENGTH SHOULD BE ADJUSTED PROPERLY AND CLAMPED NOT TO BE CONNECTED REVERSELY.
 - 2-3. NOT LOOSE THE BATTERY CABLE TERMINAL, NOR TURN THE BATTERY SWITCH OFF DURING THE ENGINE RUNNING.
3. ONLY THE SPECIFIED LOAD SHOULD BE APPLIED ON THE ALTERNATOR "L" AND "P" LINE. IT IS NOT ALLOWED TO CONNECT ANY LOAD UNSPECIFIED WITHOUT YANMAR APPROVAL.
4. CHECK ANY SURGE CURRENT OR VOLTAGE OCCURED UNDER NORMAL OPERATIONS AND EXPECTIVE ERRONEOUS OPERATIONS, AND CONFIRM THE CIRCUIT NO SURGE OCCURS. ESPECIALLY PROVIDE THE FLYWHEEL DIODE FOR "C-LOAD" AND DIODE FOR "L-LOAD".

REMARKS

1. * MARKED PARTS ARE NOT PROVIDED BY YANMAR.

NOTES FOR ENGINE STOP SOLENOID

1. PERMISSIBLE RESISTANCE OF SOLENOID CIRCUIT SHOULD BE LESS THAN 0.07Ω TO GUARANTEE PERMISSIBLE LOWEST VOLTAGE 9V TO WORK SOLENOID (PULL COIL). (TERMINAL RESISTANCE: 15/1000Ω PER COUPLER, 0Ω PER SCREW SETTING. COUPLER RESISTANCE OF SOLENOID DOESN'T NEED TO BE COUNTED) REFERENCE: AV2 (0.0088Ω/m): ≤8.0m... WITHOUT TERMINAL RESISTANCE, AV3 (0.0056Ω/m): ≤12.5m... SAME AS ABOVE. WHEN YOU EXCEED PERMISSIBLE RESISTANCE, ADOPT THE CIRCUIT IMPRESSED FROM THE POWER SUPPLY TO THE SOLENOID DIRECTLY USING A RELAY... REFER TO #
2. HIGH TEMPERATURE PARTS, SUCH AS AN EXHAUST PIPE, SHOULD NOT APPROACH FOR THE PULL POWER FALL OF SOLENOID, AND HEATING PREVENTION OF INNER COIL TEMPERATURE. (PERMISSIBLE AMBIENT TEMPERATURE: -30~100°C)
3. INSTALL FUSE TO PROTECT THE HARNESS AGAINST TROUBLES SUCH AS SHORT CIRCUIT OR CONTINUOUS DRIVE OF PULL-COIL.
4. THE POWER SUPPLY OF SOLENOID MAY NOT BE COMMON WITH THE LINE OF ALTERNATOR INITIAL EXCITATOR AS SHOWN IN THIS DRAWING. (OTHERWISE, SOLENOID MAY LOOSE STOP FUNCTION DUE TO THE POWER SUPPLY FROM ALTERNATOR "L" TERMINAL.)
5. IN CASE OF WATERPROOF CONNECT OR APPLICATION, CONNECTOR SHOULD BE FIXED BY FITTING TO PREVENT LEAD WIRE BREAK.
6. IN CASE OF EMERGENCY STOP OF MACHINE FOR SAFETY WILL BE APPLIED, SWITCH LOCATION SHOULD BE SHOWN AS A.
7. IN CASE OF THE SOLENOID CIRCUIT RESISTANCE WOULD BE LIMIT, # WIRING IS APPLICABLE.

面来歴 CAREER

Rev. 1 (30 May. 2002)
 ○ CHANGE THE NOTES FOR ENGINE STOP SOLENOID
 ○ ADD ELECTRICAL FEED PUMP (TE-02136)

Rev. 2 (20. Sep. 2002)
 ADD DIODE FOR RELAY

Rev. 3 (24. Dec. 2002)
 CHANGE SOLENOID
 ADD RELAY AND TIMER

Rev. 4 (14. Jan. 2003)
 Delete Relay (119646-77900)

Rev. 5 (5. Jun. 2003)
 CHANGE FUSE 20A→30A

Rev. 6 (21. Apr. 2005)
 ADD 129940-77010 STARTER (YDSTX-05034)

Rev. 7 (20th Feb. 2006)
 Added alternator, 119626-77210. (YDSTX-06017)

素材質量 WEIGHT (RAW) (± %)	完成質量 WEIGHT (精度%) (± %)	主席	長 SEC. MANAGER Y. Yamata	機種 MODEL 4TN V94, 4TN V98 (T)	個数 QTY.	名称 NAME WIRING DIAGRAM WIRING DIGLAM	水圧試験 HYDRAULIC TEST (MPa)	空圧試験 PNEUMATIC TEST (MPa)	小形工開発部	部長 G. MANAGER J. Mshida	技部長 MANAGER
DESIGNED H. Yokoi	DRAWN S. Shimizu	年月日 DATE 2002. 1. 29	機材 MATERIAL	ケツセンズ	YANMAR CO., LTD.	CODE E3-29906-0010	Rev. 6 [Rev. 7]	図面サイズ (C) A2			

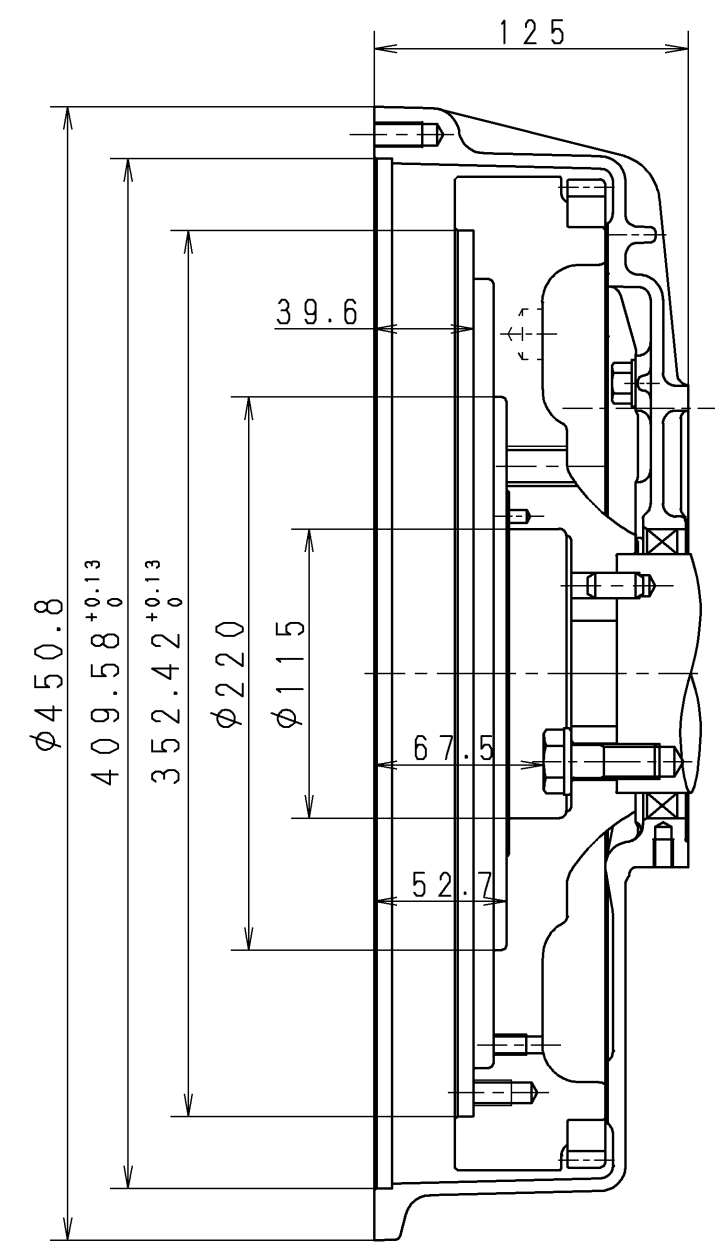
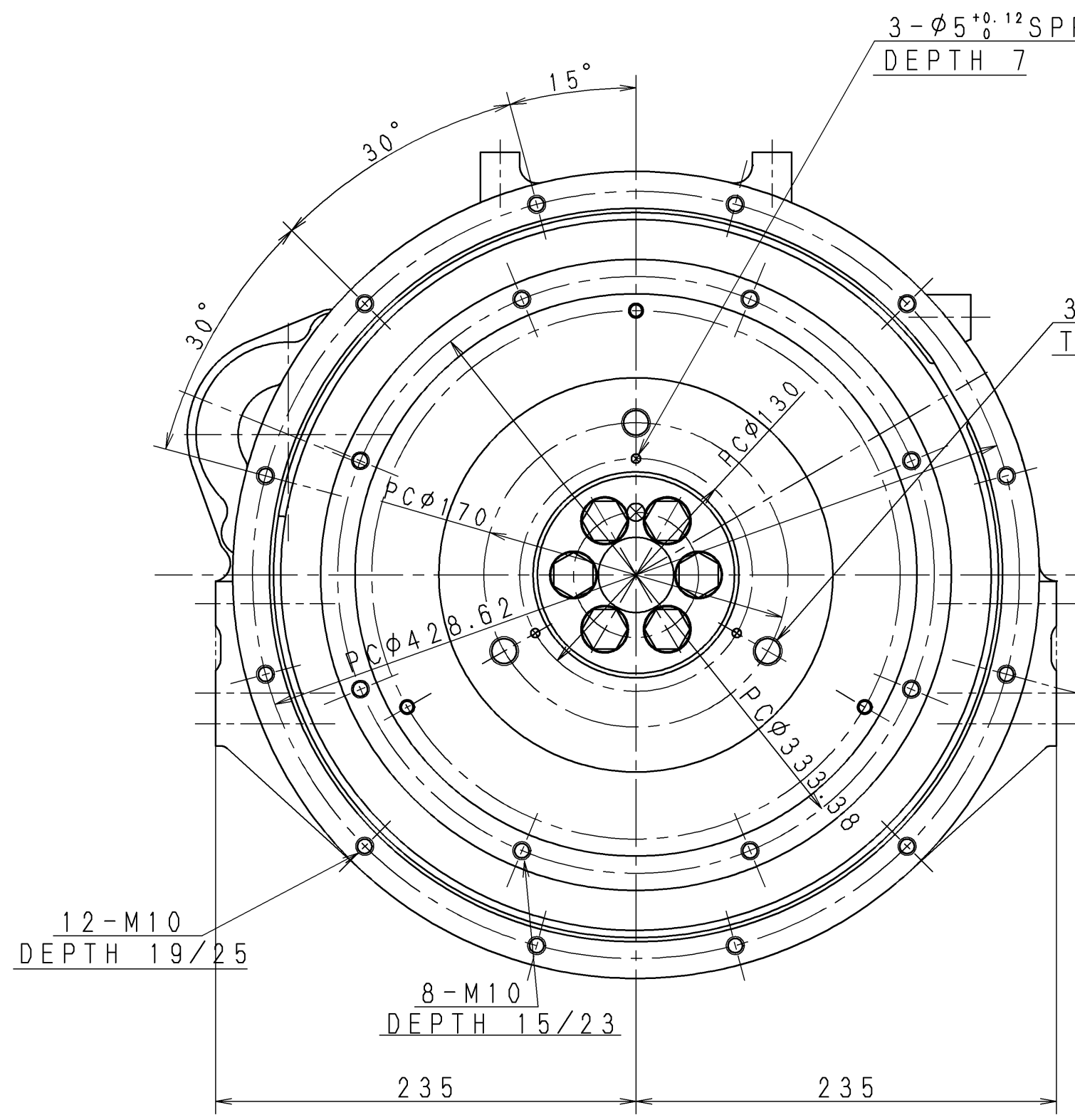

MODEL: 4TNE94/98
4TNV94L/98 (T)

Flywheel Housing	129915-01610
Flywheel CMP	129920-21580
Flywheel	129920-21410
Ring Gear	127410-21480

素材質量 WEIGHT (RAW)	(± %)
完成質量 WEIGHT (精度%)	(± %)

長 SEC. MANAGER <i>A. Kosaka</i>	来歴 CAREER Rev. 1 (04.3.3) Add TNV DI (YDSTX-04025)
検 CHECKED <i>H. Nemura</i>	機能担当者 SPECIALIST
設計 DESIGNED <i>S. Iwata</i>	製図 DRAWN <i>M. Umemoto</i>
年月日 DATE 1997 12. 4	

水圧試験 HYDRAULIC TEST (MPa kg/cm ²)	部長 MANAGER	一技長 MANAGER <i>M. Hamada</i>
空圧試験 PNEUMATIC TEST (MPa kg/cm ²)	エンジン開発部	
機種 MODEL	TNE DI TNV DI	R 度 SCALE	1/3
数量 QTY.	1 1	材質 MATERIAL	
名称 NAME	チヨツケツフ ショウサイ 直結部詳細図 (SAE # 3 COUPLING DIMENSIONS)		
Rev. 1	コード CODE	Z3-29915-0500	
	YANMAR DIESEL ENGINE CO., LTD. ENGINE DEVELOPMENT DEPT.		図面サイズ A3 (B)

重要チェックポイント	形状公差	姿勢公差	位置公差	振れ公差
真直度	線形	平行度	位置度	円筒振れ
真円度	平面度	垂直度	同軸度	全振れ公差
線形	円筒度	傾斜度	対称度	
平面度	面形			

Fig. 4TNV98T Engine performance curve

n-BxS: 4-88x90
 Displacement: 2.189L

Silencer	129004-13500
Air cleaner	5inch
CW fan	129916-44740

Crank pulley	D=130
Fan puley	D=110
φ430	PushF

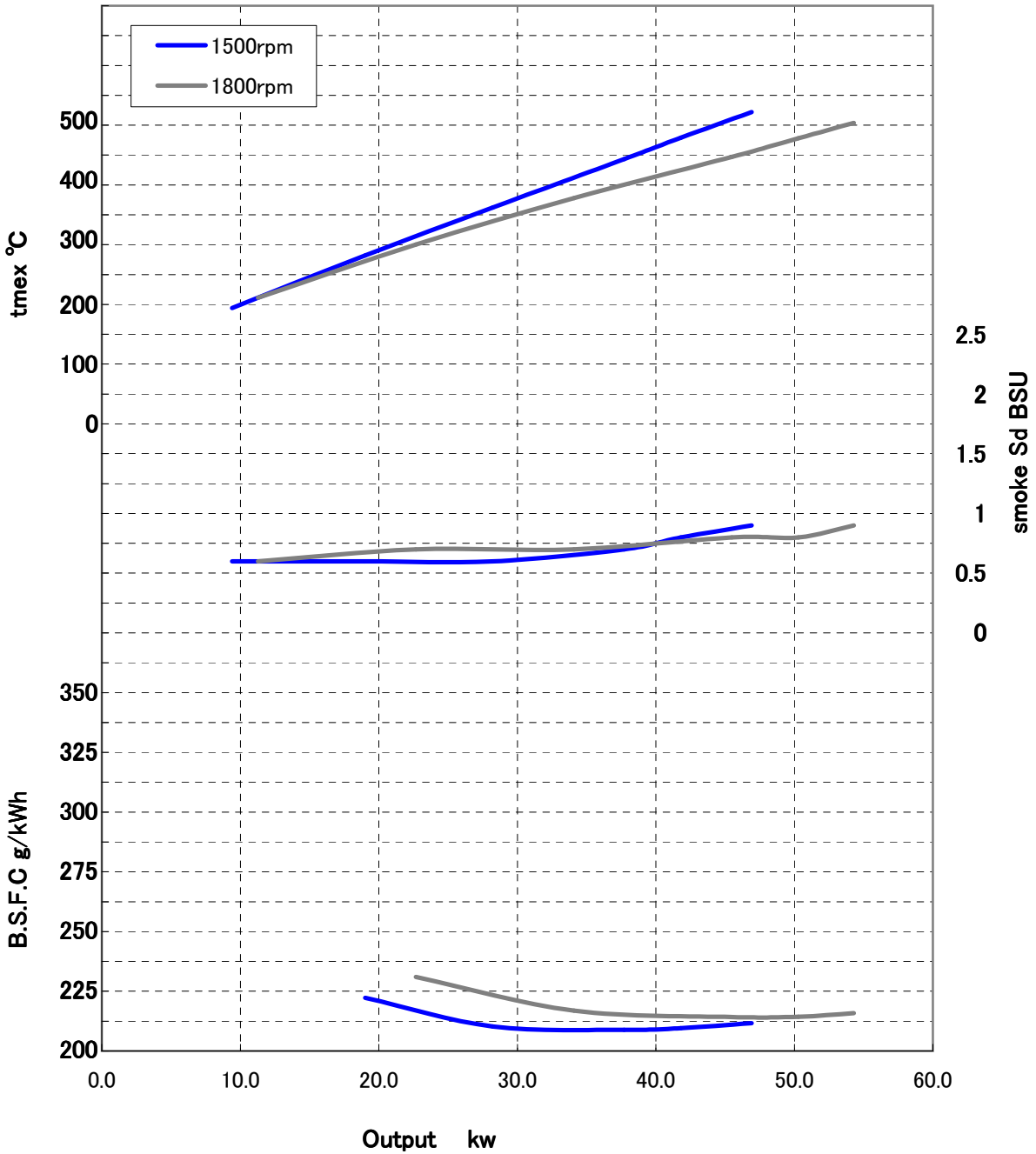

The engine operating environment and driven machine conditions must be studied carefully when selecting an engine in order to make the most of the engine performance, extend the service life and improve the machine capacity.

This manual describes the items that must be considered when selecting an engine and determining the specifications to ensure that the engine is not used beyond its capacity.

APPLICATION STANDARD

No.	Item	Application Standard		Remarks	
1	Engine type	Special swirl combustion chamber system engines (IDI engines)	Engines with cylinder bore of 76 mm or less	TNV series	
		Direct injection system engines (DI engines)	Engines with cylinder bore of 82 mm or more		
2	Output/rpm	Output rpm	See <i>Specifications on page 3-5. Engine Specifications</i>		
		Output Setting conditions	Ambient temperature	25°C (77°F)	Same as in JIS and ISO
			Atmospheric pressure	100 kPa (750 mmHg)	
			Relative humidity	30%	
Output power correction	See <i>Power Corrections on page 4-3.</i>				
3	Special operating environment	Precautions against sand dust	See <i>Special Operating Environment on page 1-5.</i>		
		Precautions for outdoor installation			
		Precautions against sea air and snow melting agents			
		Precautions against cold environment			
		Precautions against hot environment			
4	Fuel oil	Fuel oil	Ambient temperature °C (°F)	Equivalent fuel	See <i>Standard Diesel Fuel Line Layout on page 10-7</i> for the fuel specifications in each country.
		Diesel fuel	≥ -5 (23)	JIS No. 2	
			15 to -20 (59 to -4)	JIS No. 3	
			<-20 (<-4)	JIS special No. 3	
		Kerosene	Not allowed		
		Heavy oil	Not allowed		
		JP-4	Not allowed		
JP-8, JP-5	Contact Yanmar for consideration				
5	Engine oil	See <i>Engine oil on page 11-5.</i>			The initial replacement of the lubricating oil and lubricating oil filter should be done at 50 hours of service.
		Lubricating oil class	Lubricating oil replacement interval (hr)	Lubricating oil filter replacement interval (hr)	
		CD, CF, CF-4, CI-4 E-3, E-4, E-5, DH-1	Every 250	Every 250	
		Allowable maximum engine oil temperature	≤120°C (248°F)		At the specified maximum ambient temperature.
6	Engine coolant	Allowable cooling water temperature at engine outlet	≤105°C (221°F)	See <i>Cooling System on page 9-1.</i>	See <i>Engine Coolant on page 9-4.</i>
		Water quality	Soft water		
		Antifreeze mixing ratio%	Atmospheric temperature °C (°F)		See <i>Radiator on page 9-8.</i>
		30	0 to -15 (32 to 5)		
		40	-15 to -25 (5 to -13)		
		50	-25 to -40 (-3 to -40)		

APPLICATION STANDARD

No.	Item	Application Standard				Remarks
7	Power take-off (PTO)	See <i>P.T.O. Systems</i> on page 15-1.				
8	Low-temperature startability	See <i>Low-temperature startability</i> on page 1-7.				
9	Allowable inclination angle	Continuous operation	All directions	IDI	$\leq 25^\circ$	See <i>Crankcase Breather System</i> on page 11-18.
				DI	$\leq 30^\circ$	
		Instantaneous operation (within 3 minutes)	All directions	IDI	$\leq 30^\circ$	
				DI	$\leq 35^\circ$	
10	Allowable exhaust back pressure	See <i>Allowable Air Intake Restriction and Exhaust Back Pressures</i> on page 1-30.				
11	Allowable air restriction at intake manifold					

SPECIAL OPERATING ENVIRONMENT

The engine performance depends greatly on the operating and environmental conditions.

Please consult with Yanmar when unusual operating conditions exist.

Precautions Against Dusty Conditions

Condition	Part	Countermeasure
Wear due to dusty or sandy condition	Air cleaner	The following measures and cleaning are necessary to prevent dust from entering the engine: Use double element (safety element) Use evacuator valve Use dust indicator
	Alternator	Dust-proof type may be required for preventing entry of sand and dust.
	Starting motor	
	Breather air reservoir (for turbocharged engine only)	Since dust can enter from the breather pipe while the engine is stopped, an air reservoir may be installed at the end of the breather pipe.
	Cooling fan	to improve the wear resistance, a fan made of nylon 6 (reinforced with glass fiber) or steel may be required.
	V pulley	To improve the wear resistance, a hardened pulley may be required.
	V-belt	To counteract belt wear, a larger type V-belt may be required.
	Radiator	Changing the core type and fin material may be required. Heat balance check after the modification is required.

Precautions for Outdoor Installation

Condition	Part	Countermeasure
Rain, snow, etc.	Rain cap (for both air cleaner and exhaust silencer)	Entry of rainwater, snow, etc. must be prevented.
	Electrical parts	Since electrical parts correspond to level R2(*) in JIS D 0203, either install them where they will not be splashed with water, or provide covers.
Location	-----	Flat, well-ventilated place

(*) Level R2: A water spraying test level for checking the performance of the portion subject to indirect exposure to rainwater or splashing water.

Precautions Against Salty Conditions (Air, Sea Water, Road Salt)

Condition	Part	Countermeasure
Location exposed to salt air or road salt	Electrical parts	Since corrosion may occur, careful maintenance is necessary.
	Speed control lever shaft	
	Stop lever shaft	
	Exhaust manifold bolts	
	Stop lever return spring	
	Radiator	
Location where salt water may splash directly onto the engine	-----	Do not install engine where it can be splashed with salt water.

APPLICATION STANDARD

Precautions Against Cold Environment

Environmental temperature	Part	Countermeasure	Remarks
-30°C (-22°F) or above	Battery (high CCA)	Specification must be changed.	See <i>Low-temperature startability on page 1-7</i> for startability.
	Starting motor		
-30°C to -40°C (-22°F to -40°F)	Cooling water hose	Special rubber may be required to prevent rubber parts from being damaged by hardening. Choose components that will maintain flexibility at this temperature range.	
	Intake air hose		
	O-rings		
	Oil seal		
	Fuel hose		
-40°C (-40°F) or below	Fuel feed pump	An electric feed pump is required.	
	Starting aid	A block heater should be used.	
		Not recommended.	

Precautions Against Hot Environment

Environmental temperature	Part	Countermeasure
Below 40°C (104°F)	Electrical parts	The temperature inside the engine hood must be kept below 80°C (176°F) to protect the electrical parts. Provide ventilation around electrical parts.
Above 40°C (104°F)	Radiator	A large capacity radiator and fan must be used to prevent the cooling water and lubricating oil temperatures from getting too hot.
	Cooling fan	
	Oil cooler	Increase capacity or install as standard equipment.
	Electrical parts	The temperature inside the engine hood must be kept below 80°C (176°F) to protect the electrical parts. Provide ventilation around electrical parts.

Others

Condition	Part	Countermeasure
Location where explosive, flammable or toxic gas exists	-----	Engine is not designed for installation where explosive, flammable or toxic gas exists.

DIESEL FUEL SYSTEM

Layout for DI Engines with MP2 or MP4 Type Fuel Injection Pump

Fuel Line Layout for DI Engines.

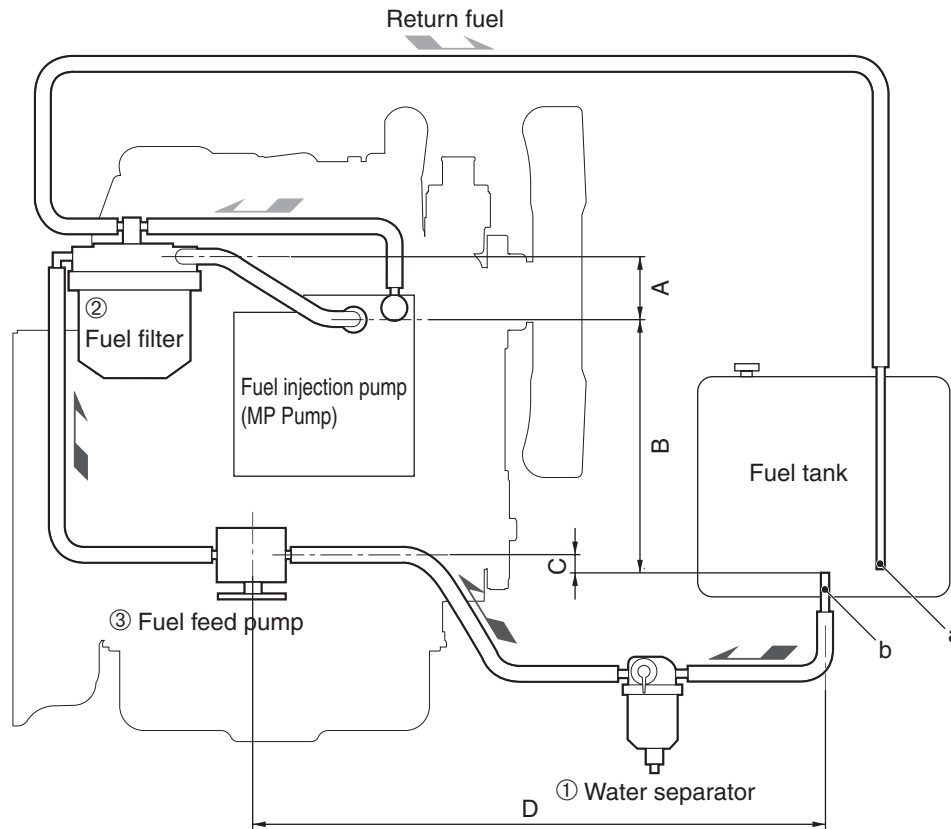

Figure 10-5

Note: Keep return line (a) away from diesel fuel outlet (b) to prevent the diesel fuel line from drawing in air and / or hot diesel fuel. NEVER connect return line (a) to the inlet line.

Diesel Fuel System Part Names and Functions for DI Engines

No.	Part name	Function
(1)	Diesel Fuel Filter / Water separator	Same as IDI engine.
(2)	Diesel fuel filter	Has 5 μm mesh paper element inside. Capacity to resist pressure is 7 kg/cm ² . There is a valve on the inlet of the fuel filter for air bleeding.
(3)	Diesel fuel pump	Sends fuel to the fuel injection pump from fuel tank.
	Electric	Mounted off the engine. Consult Yanmar before using a non-Yanmar fuel pump. An additional check valve is not necessary on the Yanmar electric fuel pump since it has one built in. Note: On a bench test, diesel fuel injection pump performance was not influenced by a minimum voltage of 10 V.

Note: Mechanical feed pump is not available for DI engines.

Fuel Line Layout (DI engines)

Position	Standard value	Content
A	50 ~ 150 mm	From fuel filter outlet to fuel injection pump inlet. For air bleeding, fuel filter outlet position should be higher than the fuel injection pump inlet position.
B	≤ 1000 mm	Total head of diesel fuel pump (from diesel fuel tank outlet to injection pump inlet)
C	≤ 400 mm	Suction head in dry conditions (from diesel fuel tank outlet to diesel fuel pump inlet)
D	≤ 2000 mm	Suppression of the suction side resistance at of the fuel feed pump (from diesel fuel tank outlet to diesel feed pump inlet)

Parts Specification for Engine

Engine model	3TNV82A ~ 4TNV98	
Diesel fuel pump	Electric type:	119225-52102 (standard), 129612-52100 (with water proof coupler)
Diesel fuel filter / water separator	Standard : Filter mesh: Water reservoir:	129242-55700 (fuel inlet & outlet horizontal) 100 mesh (with valve) 150 cc
Diesel fuel filter	Bracket: Filter: Filter mesh: Filtration size:	129004-55612 (with automatic air bleeding hole φ0.7) 119802-55800 5 μm 2000 cm ²
Engine model	4TNV98T	
Diesel fuel pump	Same as 3TNV82A ~ 4TNV98	
Diesel fuel filter / water separator	Same as 3TNV82A ~ 4TNV98	
Fuel filter	Bracket: Filter: Filter mesh: Filtration size:	123907-55610 123907-55800 5 μm 5000 cm ²

For poor quality fuel

3TNV82A to 4TNV98	Filter Filter mesh Filtration size	129004-55800 1 μm 1650 cm ²	129907-55800 1 μm 4000 cm ²
4TNV98T	Filter Filter mesh Filtration size	129907-55800 1 μm 4000 cm ²	

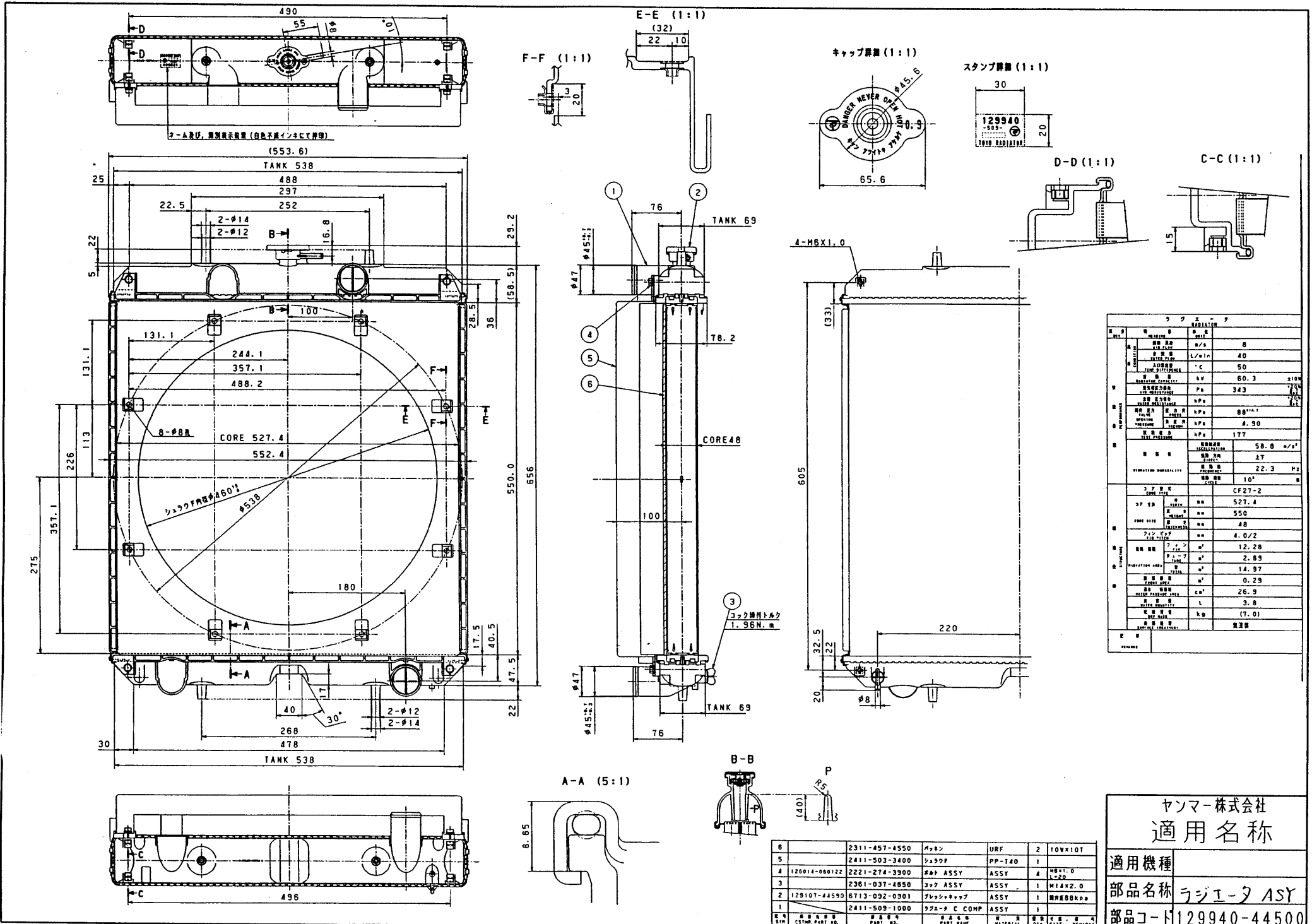

ラジエータ		SPECIFICATION	
型式	RF-2	冷却液	水
容量	40	冷却能力	50
冷却液	水	冷却能力	60.3
冷却液	水	冷却能力	34.3
冷却液	水	冷却能力	88.1
冷却液	水	冷却能力	4.90
冷却液	水	冷却能力	177
冷却液	水	冷却能力	58.8
冷却液	水	冷却能力	27
冷却液	水	冷却能力	22.3
冷却液	水	冷却能力	10
冷却液	水	冷却能力	CF27-2
冷却液	水	冷却能力	527.4
冷却液	水	冷却能力	550
冷却液	水	冷却能力	48
冷却液	水	冷却能力	4.0/2
冷却液	水	冷却能力	12.28
冷却液	水	冷却能力	2.85
冷却液	水	冷却能力	14.97
冷却液	水	冷却能力	0.29
冷却液	水	冷却能力	26.9
冷却液	水	冷却能力	3.8
冷却液	水	冷却能力	(7.0)

ヤンマー株式会社	
適用名称	
適用機種	ラジエータ ASY
部品名称	ラジエータ ASY
部品コード	129940-44500

YANMAR CO., LTD.

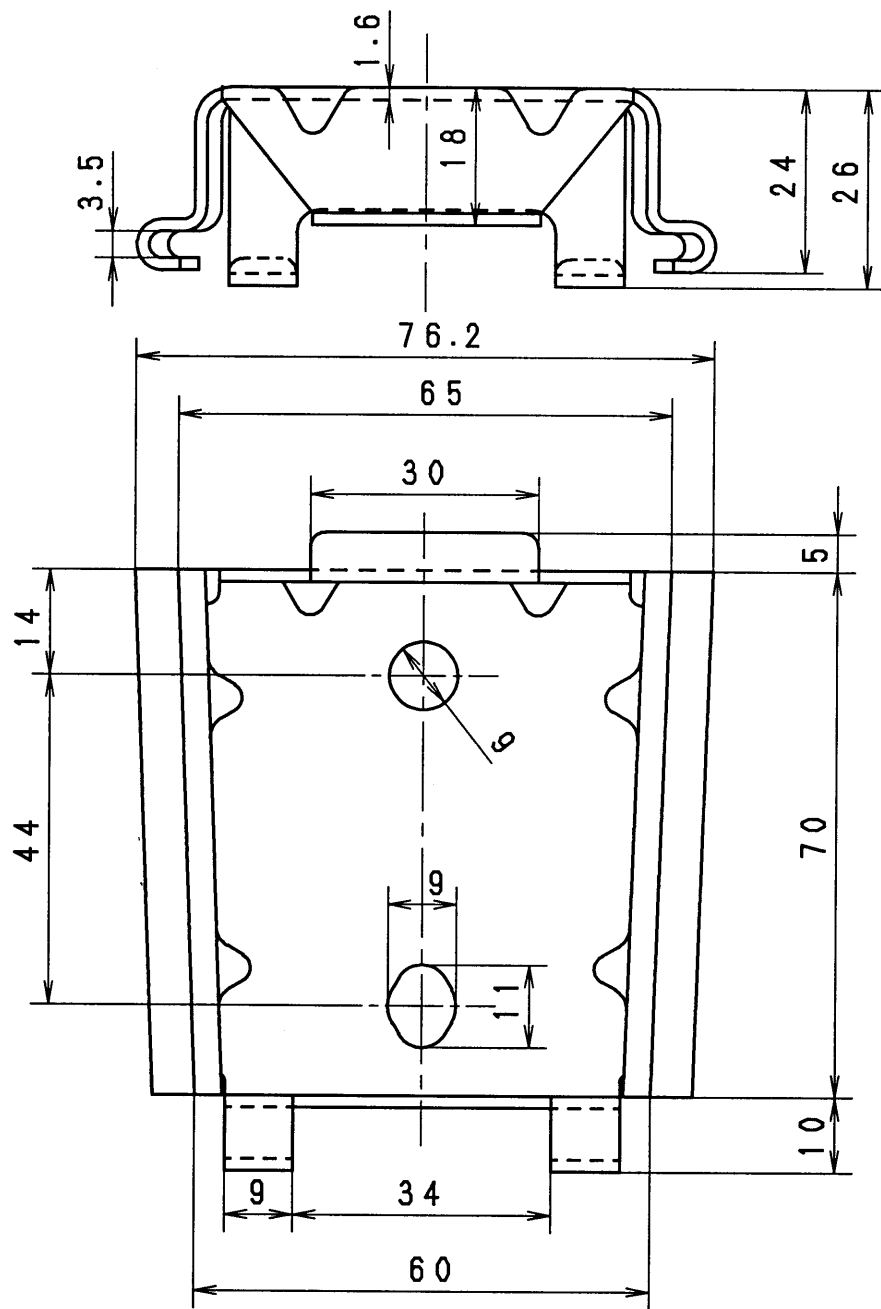

ブラケット (サブタンク)

ヤンマーディーゼル株式会社
YANMAR DIESEL ENGINE CO., LTD.

DWG. NO. _____

部品コード

120445-44540

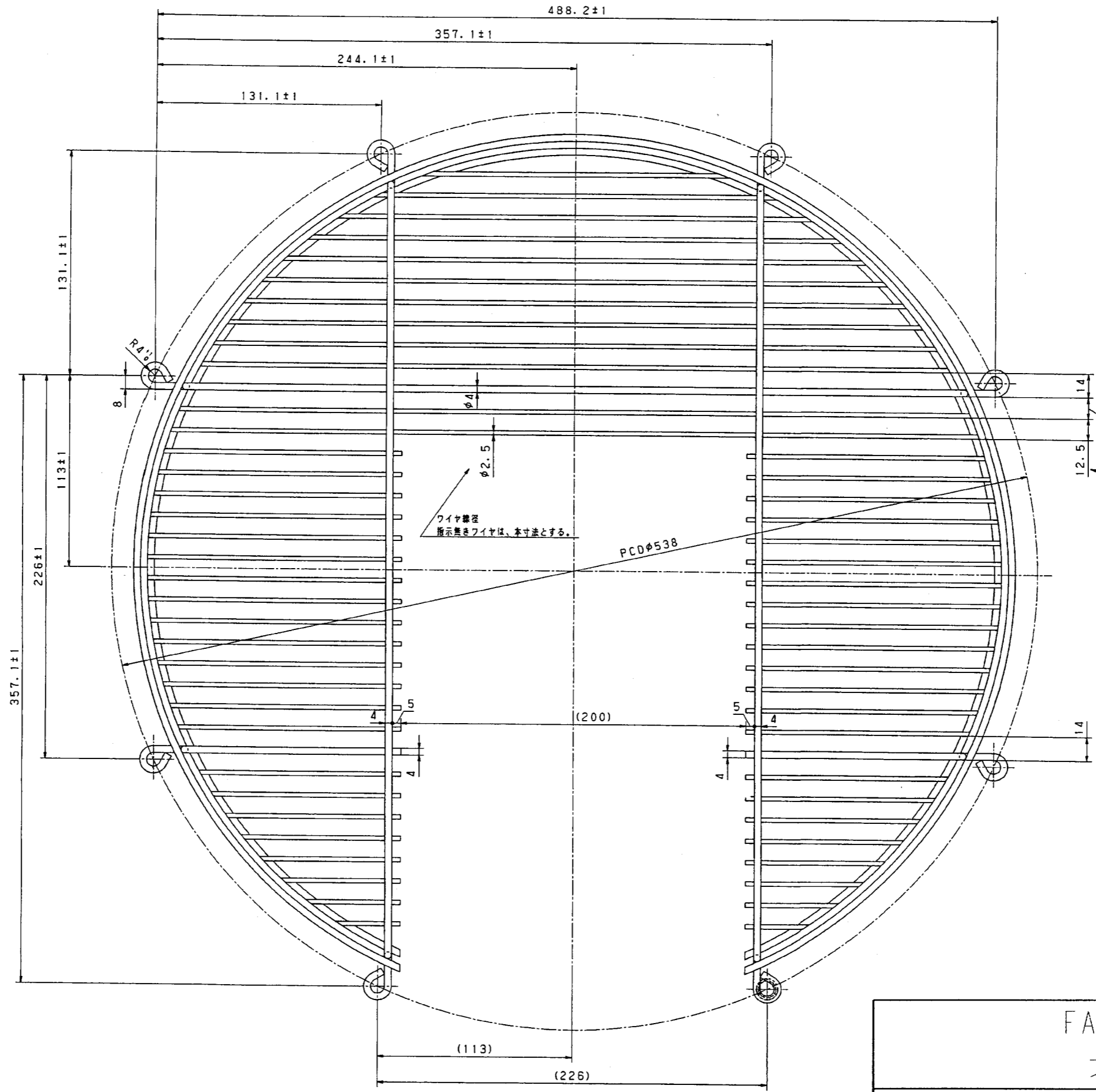
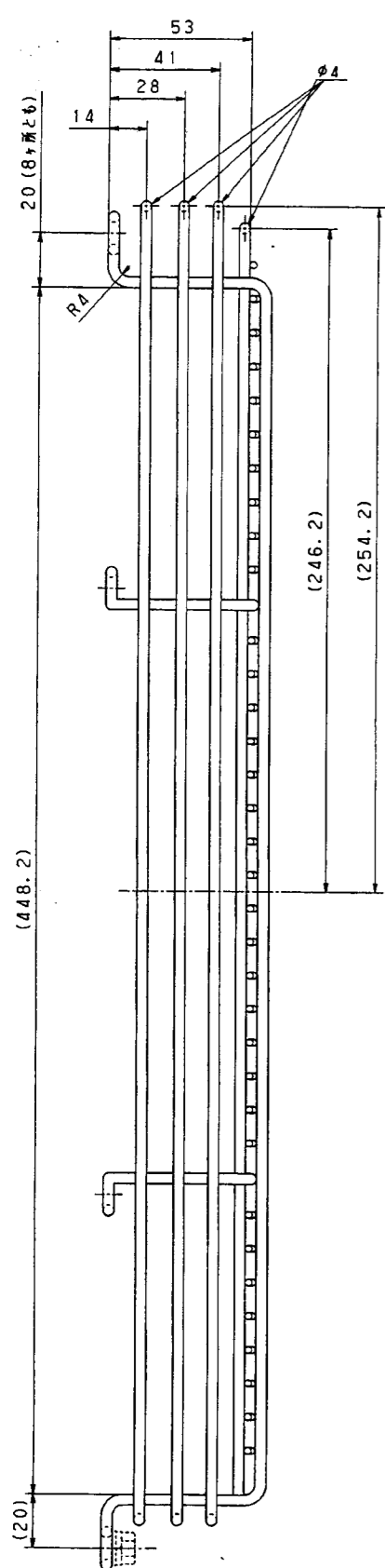

ワイヤ間ピッチ
指示無きピッチは本寸法とする。

ワイヤ線径
指示無きワイヤは、本寸法とする。

FAN GUARD ファンガード	
YANMAR ENGINE PRODUCT OPERATIONS DIV., YANMAR CO., LTD.	DWG. CODE NO. 129907-44560

備考

1. 材質: CR, J4 硬度 $70^{\circ} \pm 5^{\circ}$

Note

material: CR

rubber hardness: $70^{\circ} \pm 5^{\circ}$

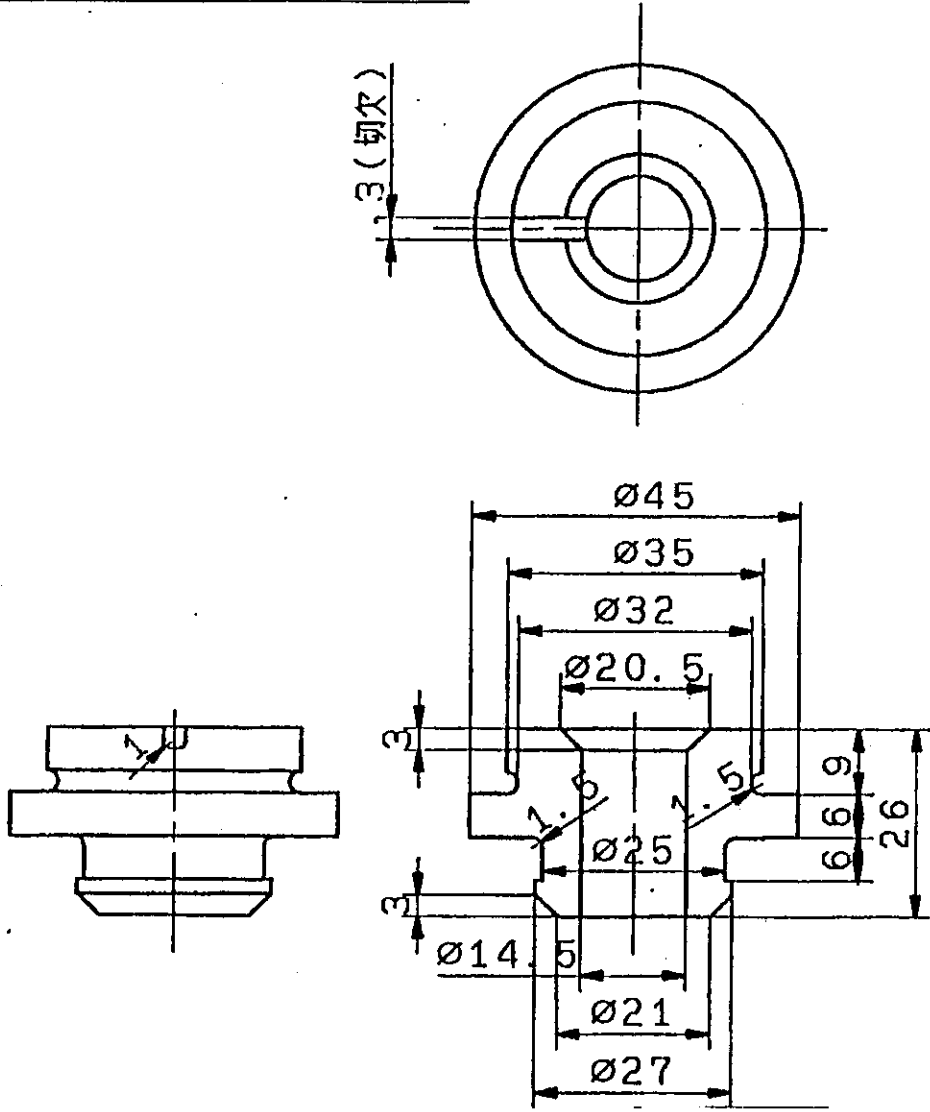

Dumper

Silent blocks

ヤンマーディーゼル株式会社	
適用名称	
適用機種	
部品名称	円板ゴム座
部品コード	119255-44660

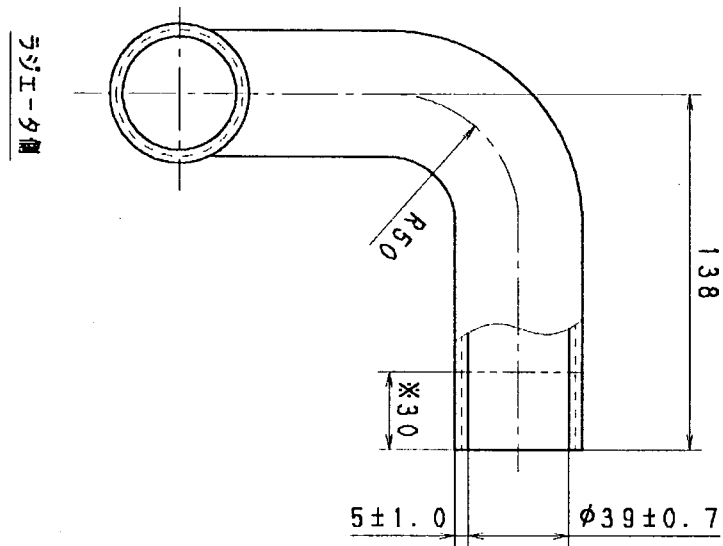
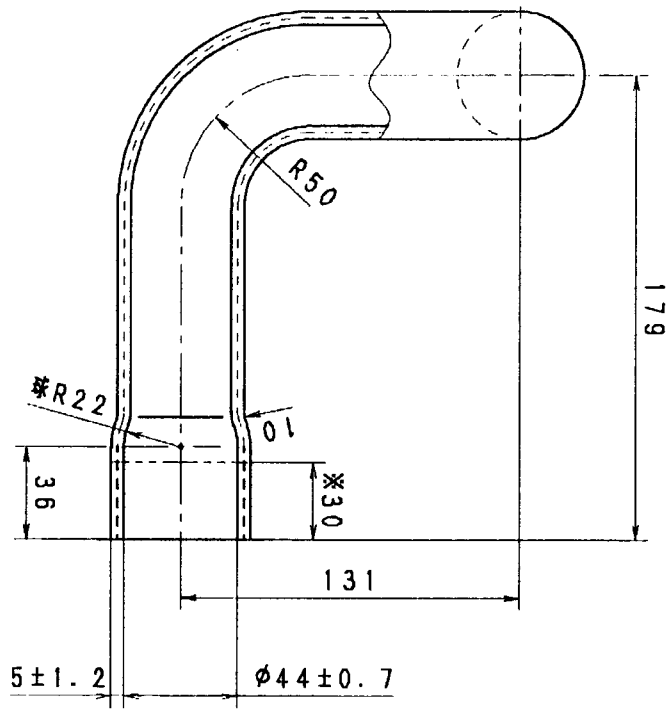

CWP 側

YANMAR DIESEL ENGINE CO., LTD	
部品名称 PART NAME	CW-T (A) 冷却水管 (A)
PART No.	129981-49050

3D-CAD

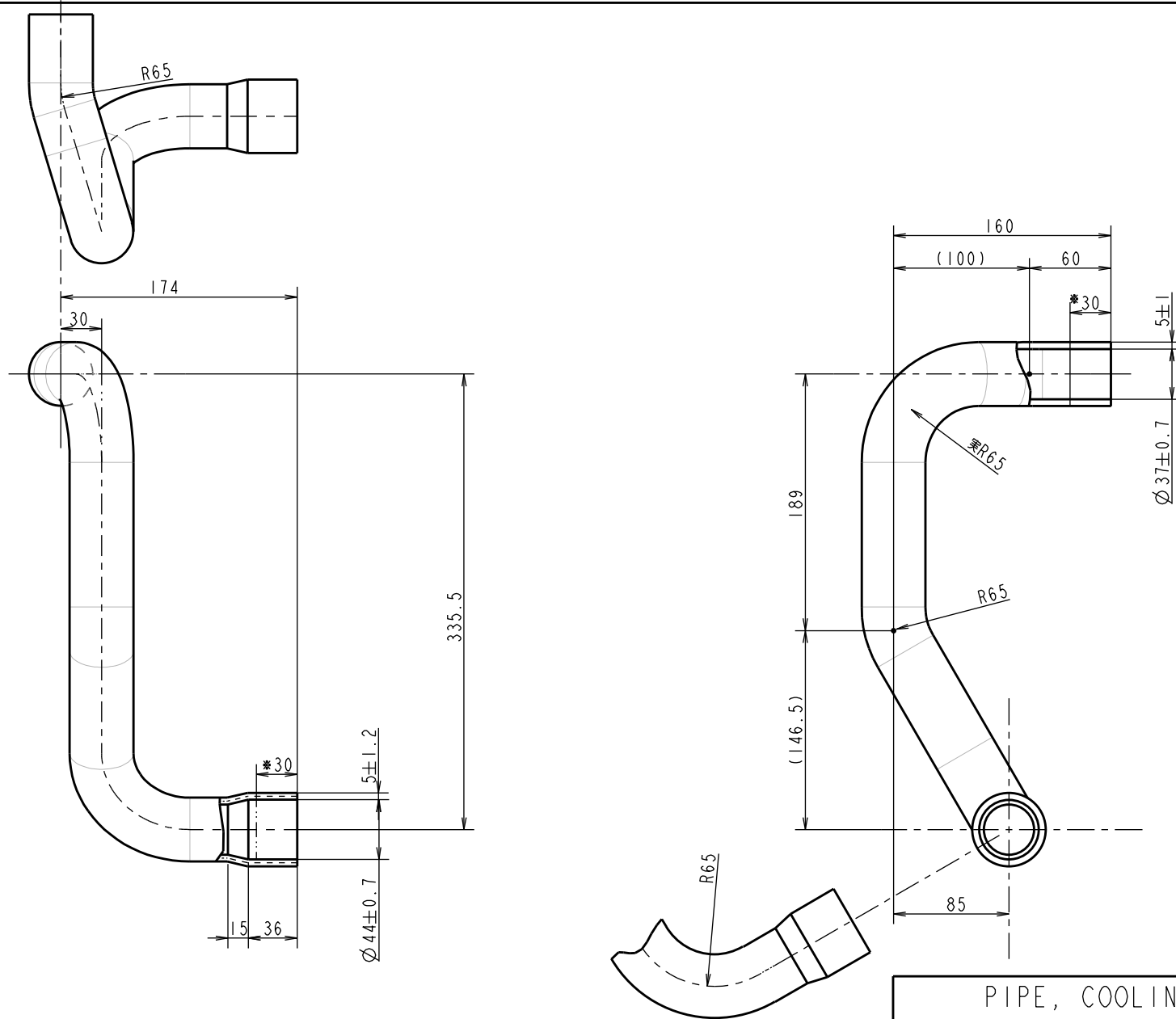

PIPE, COOLING WATER
CW-T(B)

YANMAR

ENGINE PRODUCT OPERATIONS DIV., YANMAR CO., LTD.

CODE 129981-49062

ENG. MODEL ??????

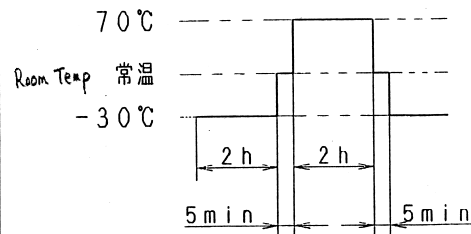
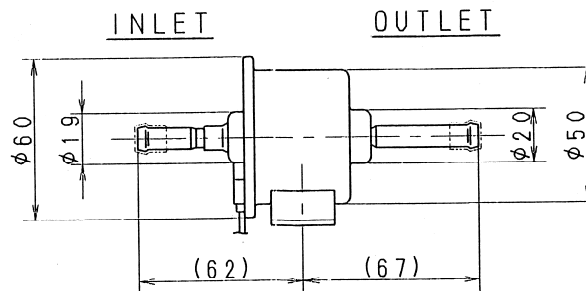
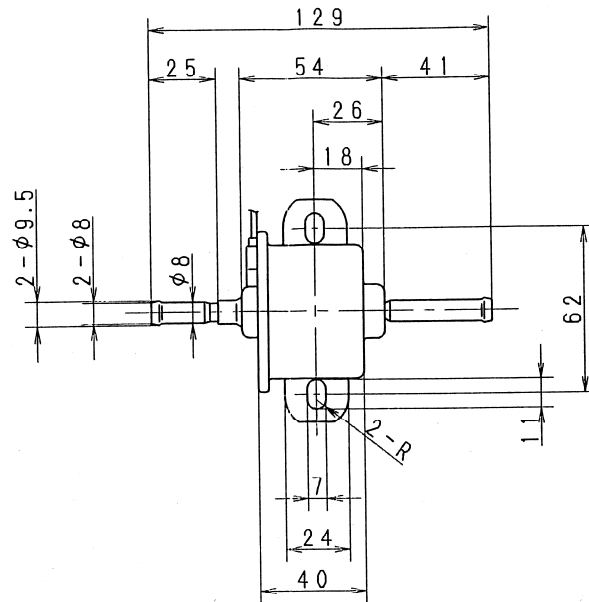
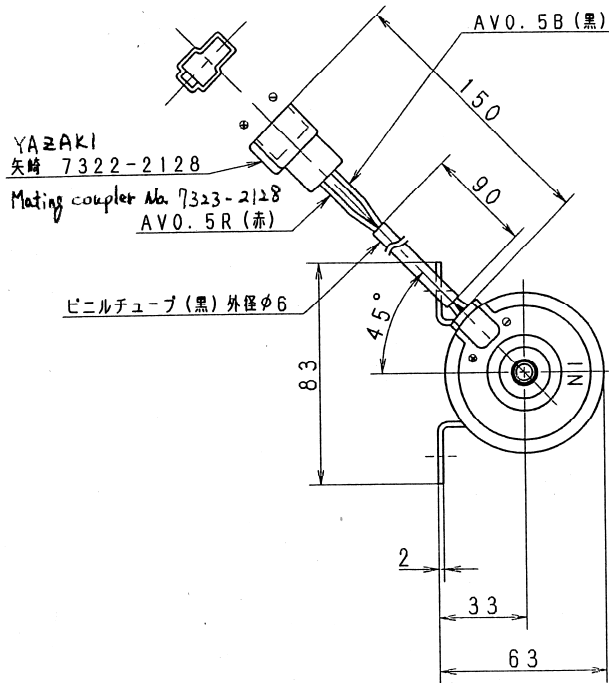

☒ 1

NOTES FOR OPERATING FUEL PUMP

1. USE A 100 MESH FILTER (PAPER TYPE) BETWEEN PUMP AND FUEL TANK
2. FIX A PUMP INLET & OUTLET PIPES HORIZONTALLY OR VERTICALLY (OUTLET IS UP SIDE)
3. PUT A CLIP AT HOSE INSERTING PLACE
4. DON'T OPERATE WITHOUT FUEL

- SPECIFICATIONS
(ROOM TEMPERATURE CHARACTERISTIC,
MEASUREMENT METHOD AND EQUIPMENT
ARE BASED ON JIS D3606)
1. RATED VOLTAGE: 12V DC
 2. OPERATING VOLTAGE RANGE: 8.5-16.5V
 3. OPERATING CURRENT: MAX 1.5A
 4. DELIVERY: MIN 400cc/min AT FREE FLOW (0.1kgf/cm² TOTAL PRESSURE)
 5. TOTAL PRESSURE (DELIVERY + SUCTION): MAX 0.38kgf/cm² AT ZERO DELIVERY
 6. SUCTION PRESSURE AT DRY CONDITION: MAX -30mmHg
 7. AIR TIGHTNESS: SHOULD HAVE NO LEAKAGE UNDER A PRESSURE OF 1kgf/cm² APPLIED TO INLET AND OUTLET FOR 15 SECONDS
 8. OPERATING TEMP. RANGE: -30-70°C
 9. TEST FUEL: JIS K2203 OR K2201
 10. FIXING DIRECTION FOR TEST: INLET & OUTLET PIPES HORIZONTALLY
 11. WEIGHT: 600g
 12. SURFACE TREATMENT: SEE BELOW
 13. FUEL TIGHTNESS OF CHECK VALVE THE AMOUNT OF LEAK TO OUT SIDE SHALL BE MAX 5cc/min WHEN PRSSURIZED 0.06kgf/cm² FROM IN PORT WITH GASOLINE

AFTER EACH TEST (NO.14-24) AS FOLLOWS,
PUMP MUST OPERATE NOMALLY

14. VIBRATION: JIS D1601 5.3(1) STEP4
15. WATER PROOF: JIS D0203 DI SHOULD BE NO WATER INSIDE OF PUMP
16. THERMAL SHOCK:
 - a) PATTERN: SEE FIG 1
 - b) CYCLES: 4
17. THERMAL RESISTANCE:

PATTERN: 70°C 240Hrs AND -20°C 240Hrs
18. HIGH TEMP. PERFORMANCE:
 - a) VOLTAGE: 14V DC
 - b) FUEL TEMP.: 50°C
 - c) ENVIRONMENT TEMP.: 70°C
 - d) OPERATING TIME: 96Hrs
19. FALLING TOUGHNESS:

FALL FROM 300mm HEIGHT TO THE CONCRETE
20. SURGE VOLTAGE: JASO D001-22 A-1,2 B-1,2 ALL
21. REVERSAL VOLTAGE APPLING:

JASO D001-22, 13V FOR 1min
22. DURABILITY TEST: AFTER TEST AS FOLLOWS, DROP OF DELIVERY SHOULD BE LESS THAN 10%
 - a) VOLTAGE: 14V
 - b) THERMAL ENVIRONMENT: ROOM TEMPERATURE
 - c) OPERATING TIME: 1000Hrs

23. DRY PUMPING DURABILITY:

- a) VOLTAGE: 14V DC
- b) PATTERN: 5min ON-OFF
- c) CYCLES: 10

24. WATER PROOF DURABILITY TEST

- a) OPERATING IN THE AIR: 1Hr
 - b) STOPPING IN THE WATER: 1Hr
 - c) CYCLES: 350
- } 1 CYCLE

YANMAR DIESEL

PARTS NAME	FUEL FEED PUMP
PARTS CODE	119225-52102

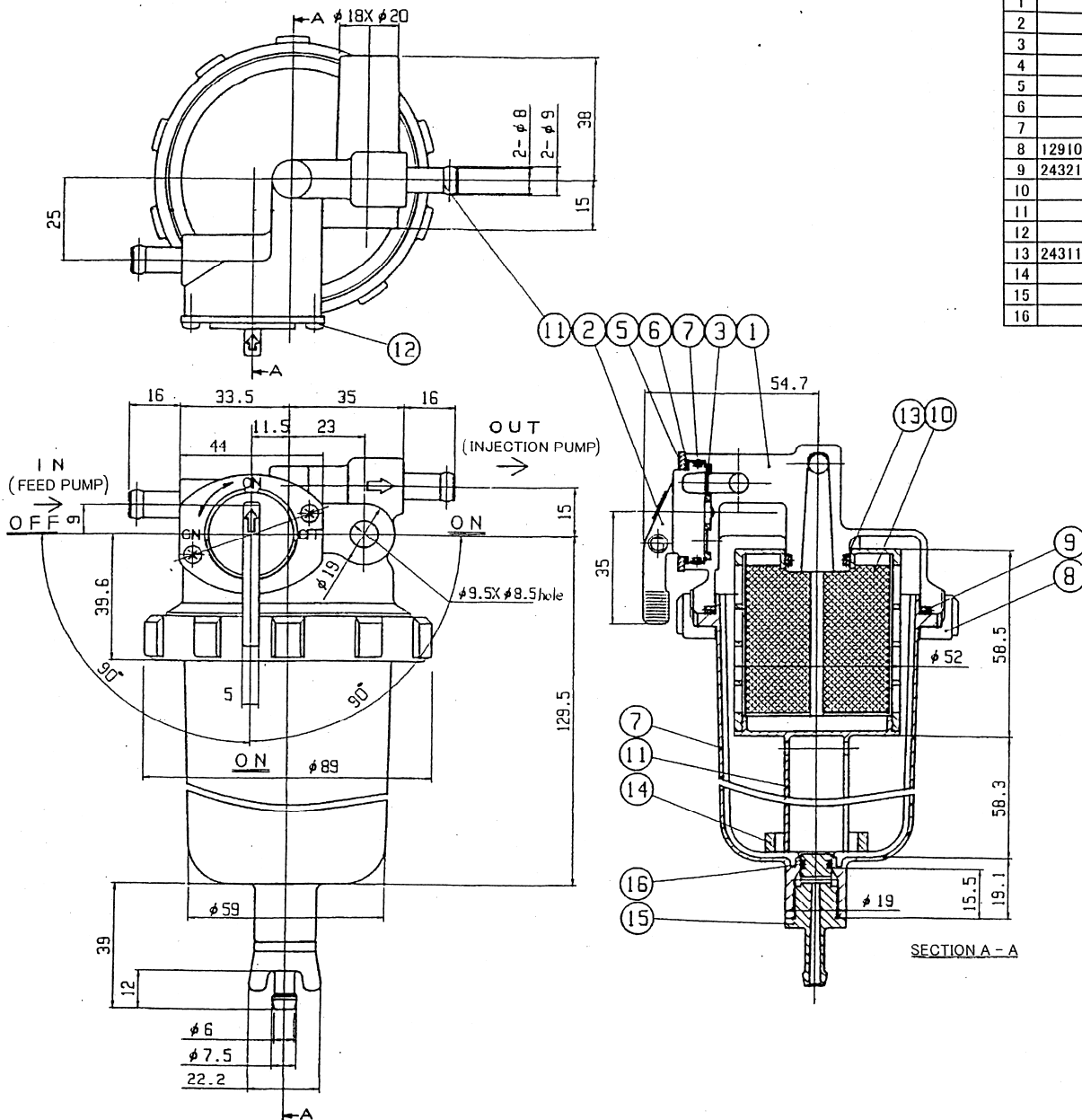

NO.	YANMAR CODE	SUPPLIER CODE	MODEL NAME	MATERIAL	QUANTITY	NOTES
1		YD-259-1	BODY	ADC12	1	
2		DI-2a	LEVER	ZDC2	1	WHITE CHROMATE
3		OK-3a	VALVE PACKING	NBR	1	
4		KTO-2-4	WAVE WASHER	SKS	1	
5		DI-5a	PLATE	SPCC	1	MFZn2
6		YMO-1-26	O RING	NBR	1	S-29
7		YD-259-7	CUP	12 NYLON	1	SEMI-TRANSPARENT
8	129100-55690	IA-8	RING NUT	ZDC2	1	WHITE CHROMATE
9	24321-000650	IA-9	O RING	NBR	1	G65
10		YD-259-10	ELEMENT	66 NYLON	1	108 MESH
11		S12-08	JOINT	C2700T	2	
12		ZSR-30-13	SCREW	S25C	2	MFZn2-C
13	24311-000160	YM-5-6	O RING	NBR	1	P16
14		JB-14-12	FLOAT	P.P	1	RED
15		JB-13-18	DRAIN PLUG	PCM	1	
16		KG-6	O RING	NBR	1	P7

SPECIFICATION		
ITEM	CONDITION	STANDARD
AIRTIGHTNESS	AIR PRESSURE(100kPa)(1.0kg/cm ²)	NO LEAKAGE
FLOW RATE		
LEVER OPERATION TORQUE	AFTER OPERATING A FEW TIMES	LESS THAN 0.7N·m (7kg·cm)
ADAPTIVE FUEL		LIGHT OIL, YANMAR HEAVY OIL
ADAPTIVE TEMPERATURE RANGE		-20°C ~ 80°C
LEVER OPERATION DURABILITY	OPERATION SPEED 15±5 REPROICATION/min	1X103 REPROICATION

NOTE

- ① ASSEMBLE AND APPLY DIAMOND GREASE TO RING NUT SCREW.
TIGHTNING TORQUE: 15⁺⁵ N·m (150+50 kg·cm)
- ② FORCE FIT AFTER APPLYING ADHESIVE (THREE BOND 1303) TO JOINT.
DRAFT LOAD: MORE THAN 4 N·m (40kg)
- ③ ELEMENT SPECIFICATIONS
FILTRAION AREA: MORE THAN 57cm²
OPENING: 152 μ
- COUNTER VIBRATION: 8G, 50Hz
- CAPACITY OF WATER-OIL SEPARTOR: MORE THAN 150cc
- TO BE FREE FROM FOREIGN MATTERS AND BARRIS IN FUEL LINE.
- INDICATED DETAIL OF DATE OF MANUFACTURE (ex.) 2001.5.14 [N15]

DAY 1-26, 27, 28, 29, 30, 31 YEAR 0-9 MONTH 1-9, 10, 11, 12
(A-Z) (a) (b) (d) (e) (f) THE END OF NUMBER OF THE YE/ (1~9)(O) (N) (D)

YANMAR DIESEL	
PARTS NAME	WATER-OIL SEPARATOR
PARTS CODE	119802-55700

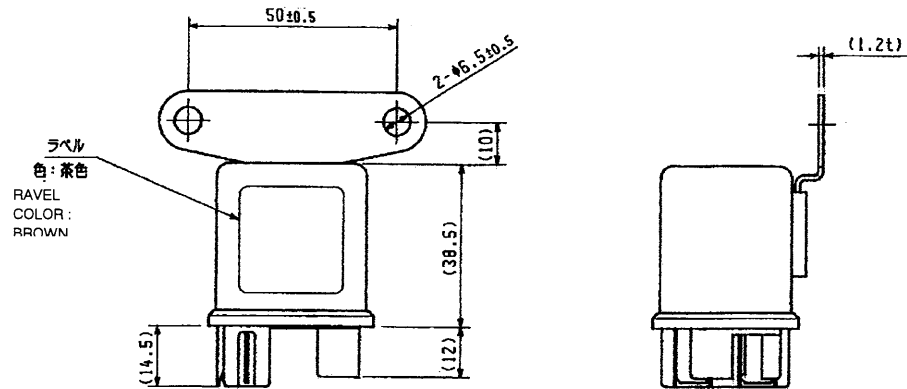

ラベル
色: 茶色
RAVEL
COLOR:
BROWN

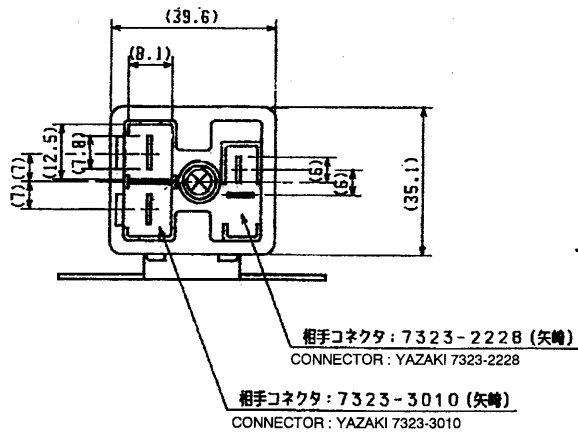

相手コネクタ: 7323-2228 (矢崎)
CONNECTOR: YAZAKI 7323-2228

相手コネクタ: 7323-3010 (矢崎)
CONNECTOR: YAZAKI 7323-3010

仕様

1. 定格電圧 : DC12V
2. 連続定格 : 10 MIN.
3. コイル抵抗値 : 37Ω
4. インダクタンス : 66mH (at 1kHz)

SPECIFICATIONS

1. RATED VOLTAGE : DC12V
2. MAXMUM OPERATING TIME : 10 MIN.
3. COILE RESISTANCE : 37 ohm
4. INDUCTANCE : 66mH (at 1kHz)

YANMAR DIESEL ENGINE CO., LTD.
ENGINE DEVELOPMENT DEPT.

MODEL

TNE SERIESE

部品名称

グローリレー

NAME

GLOW RELAY

PART No.

119650-77910

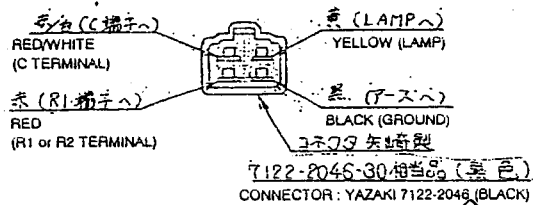
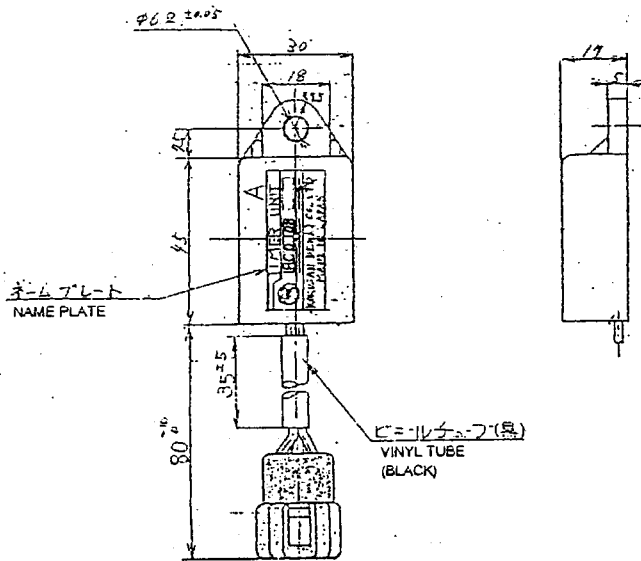

-30-

仕様

1. リレーON時間 : 15±3 (sec.)
2. 使用温度範囲 : -25°C~+80°C
3. 保存温度範囲 : -25°C~+80°C
4. 使用電源電圧範囲 : 8V~15V
5. 適用リレー仕様 : 12V 励磁電流 : 1 A
6. 耐水性 : 清水中10cmノ所ニ24時間保持シタ後、水分ヲ拭キ取り自然乾燥後、性能ニ異常ナキコト。但シ、カブラ及ビコネクタ部分ハ浸水ガ無イヨウニ行ウコト。
7. 耐振性 : 20G一定ニテ100~1000Hz60secスイープニテX, Y, Z方向各 2 Hr 振動ヲ与エ性能ニ異常ナキコト。但シ、ワイヤーハーネスハ共振ナキヨウ取り付ケルコト。
8. 耐久性 : 30000サイクル動作サセタ後性能ニ異常ナキコト。

SPECIFICATIONS

1. OPERATION TIME : ON AFTER 15 sec.
2. USABLE TEMPERATURE RANGE : -25°C~+80°C
3. PRESERVE TEMPERATURE RANGE : -25°C~+80°C
4. USABLE VOLTAGE RANGE: 8V~15V
5. APPLICABLE RELAY : 12V
6. WATERPROOFING : DO NOT EXPOSED TO THE RAIN ON CONNECTOR AND TERMINAL.
7. VIBRATION RESISTANCE : 20G
8. DURABILITY : 30000 cycle

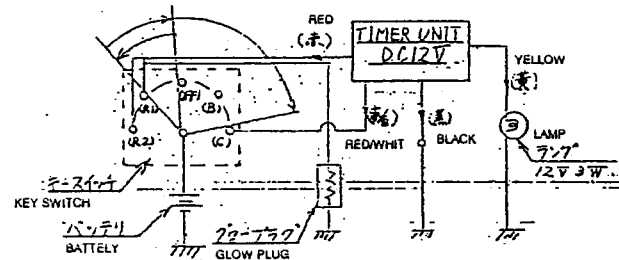
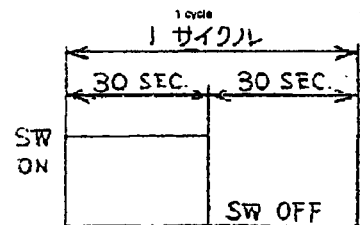

結線図
WIRING
DIAGRAM

MODEL	TNE SERIESE
部品名称	ランプタイマ
NAME	TIMER,GLOW PLUG
PART No.	128300-77920

3D-CAD

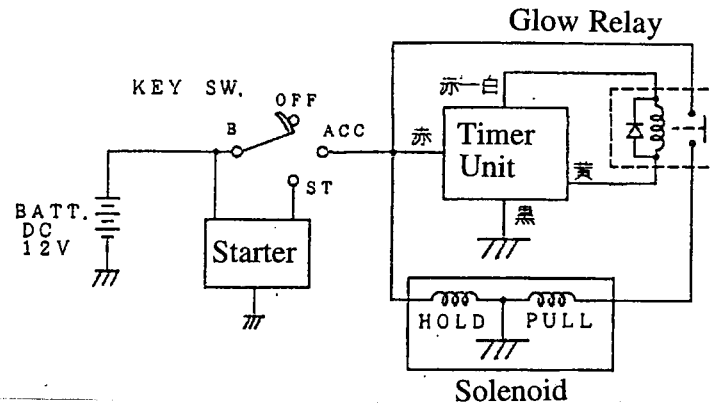
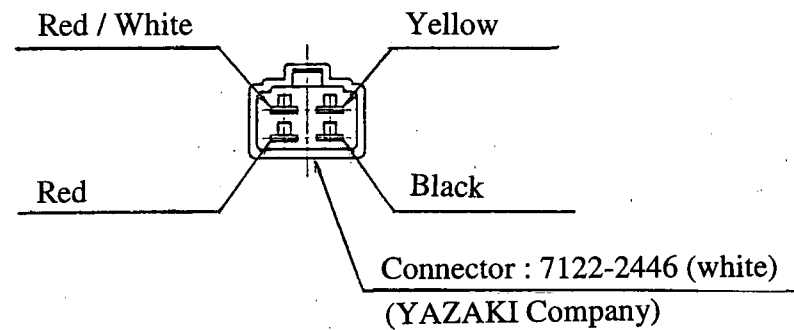
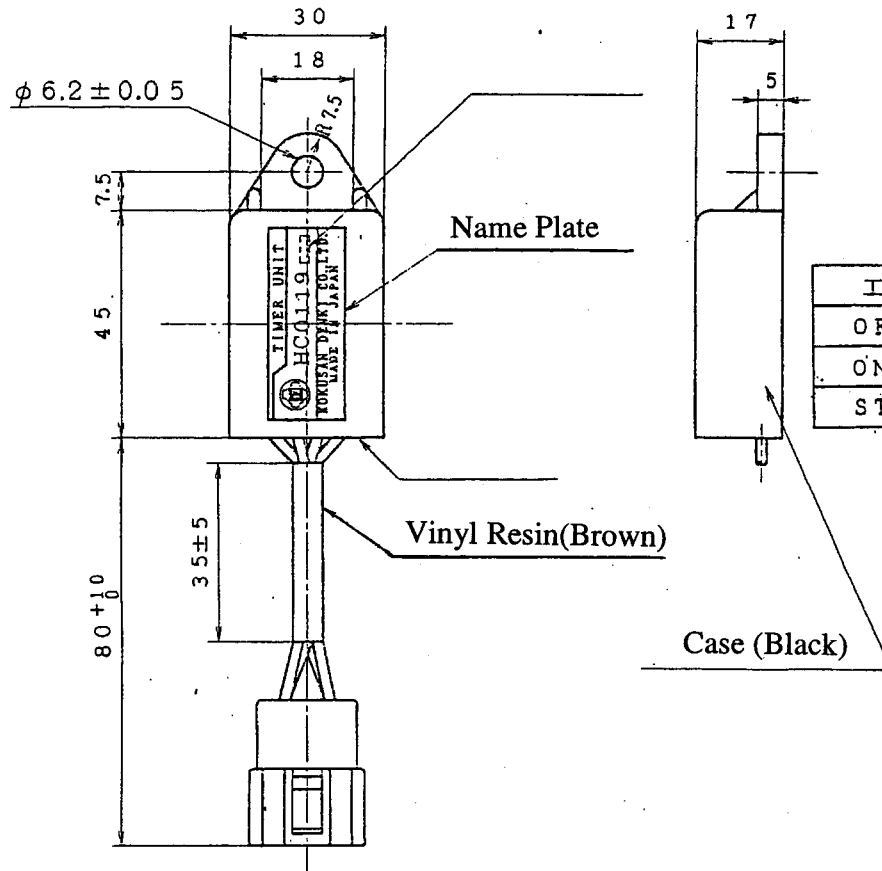

工種	B	ACC	ST
OFF			
ON	○	○	
ST	○	○	○

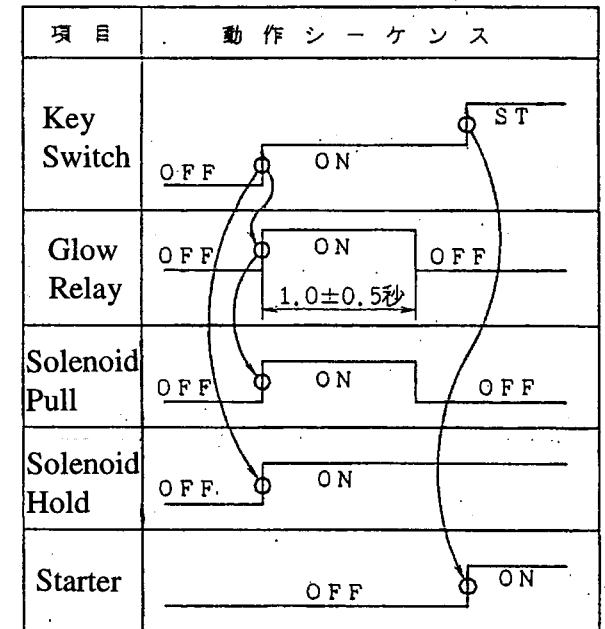

TIMER (1 sec)
タイマー (1 sec)

YANMAR	CODE	129211-77920
ENGINE PRODUCT OPERATIONS DIV., YANMAR CO., LTD.		