

L48 Pump

No	Base	Sales area	Model
1	L-N	Global	L48N6DA1F1AA
2		Asia	L48N6-PEYI
3	L-V	Euro	L48V6VDA1F8AA

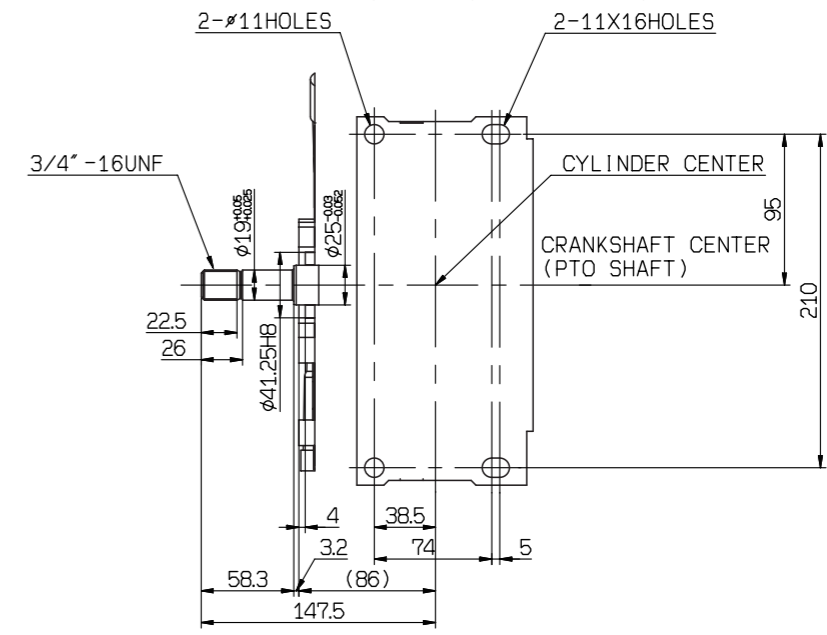

ENGINE MOUNTING PLATE AND PTO SHAFT
SEEN THROUGH FROM THE TOP OF THIS ENGINE

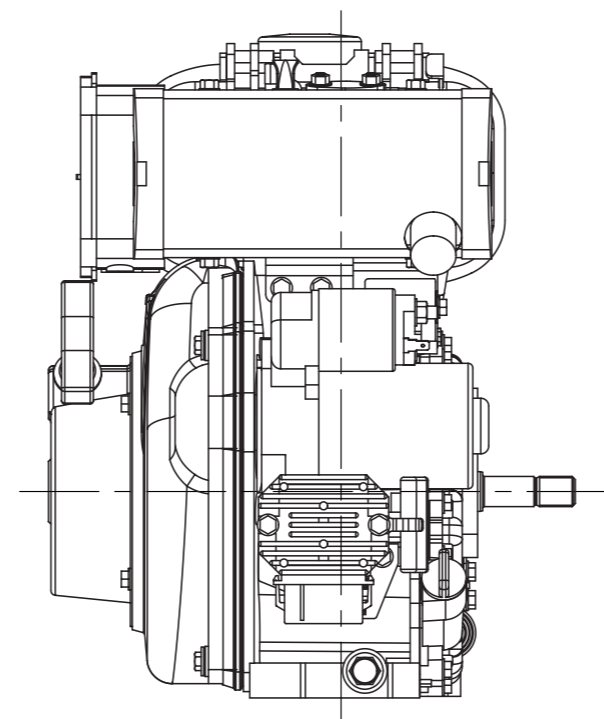
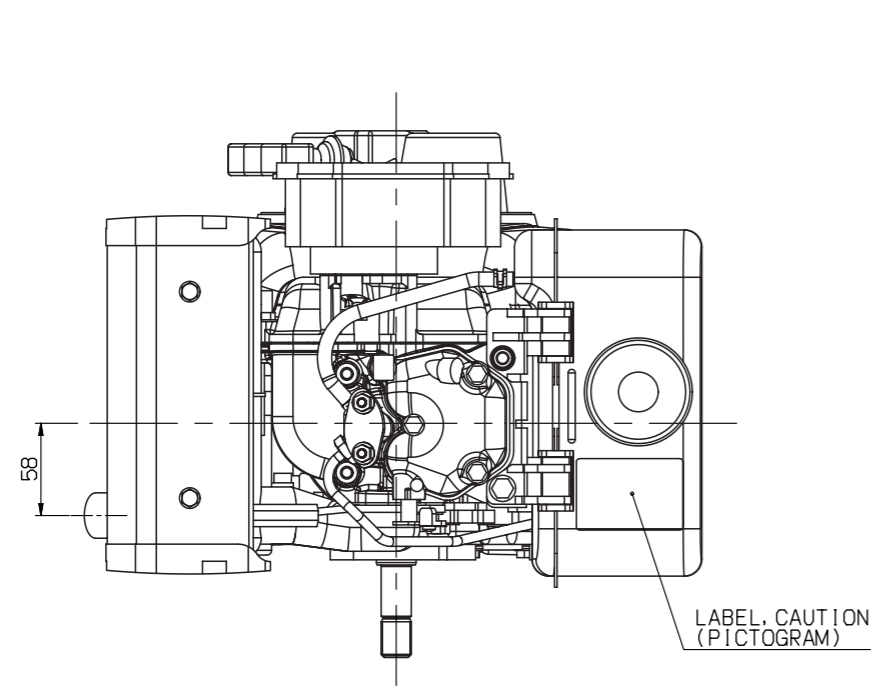
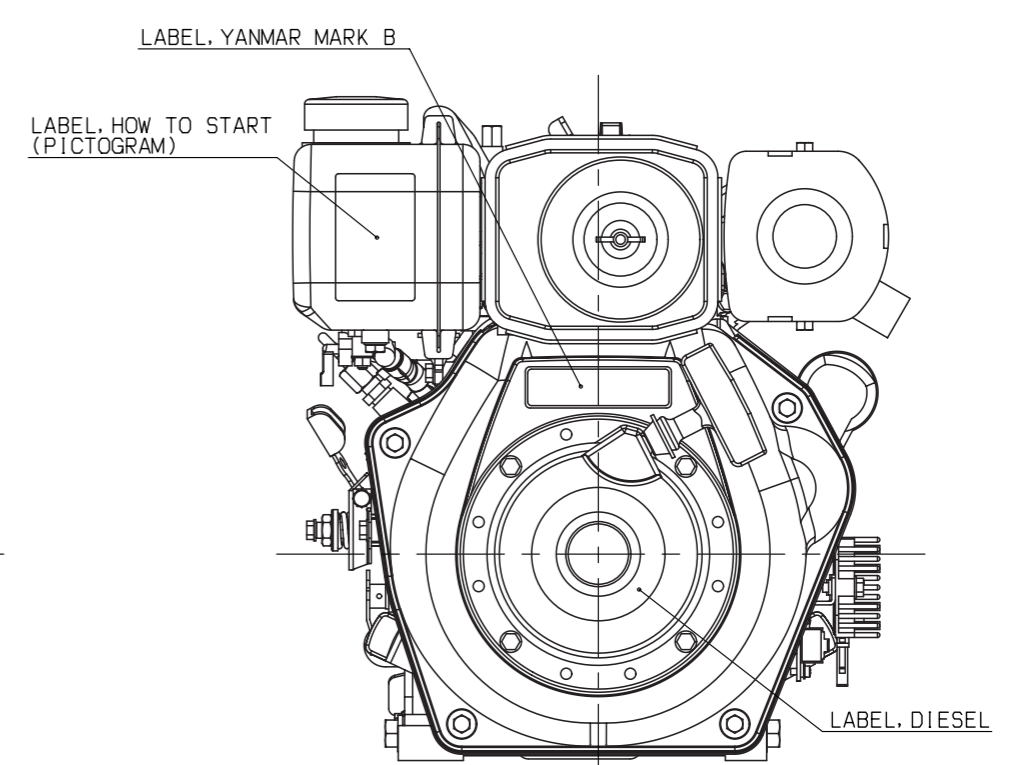
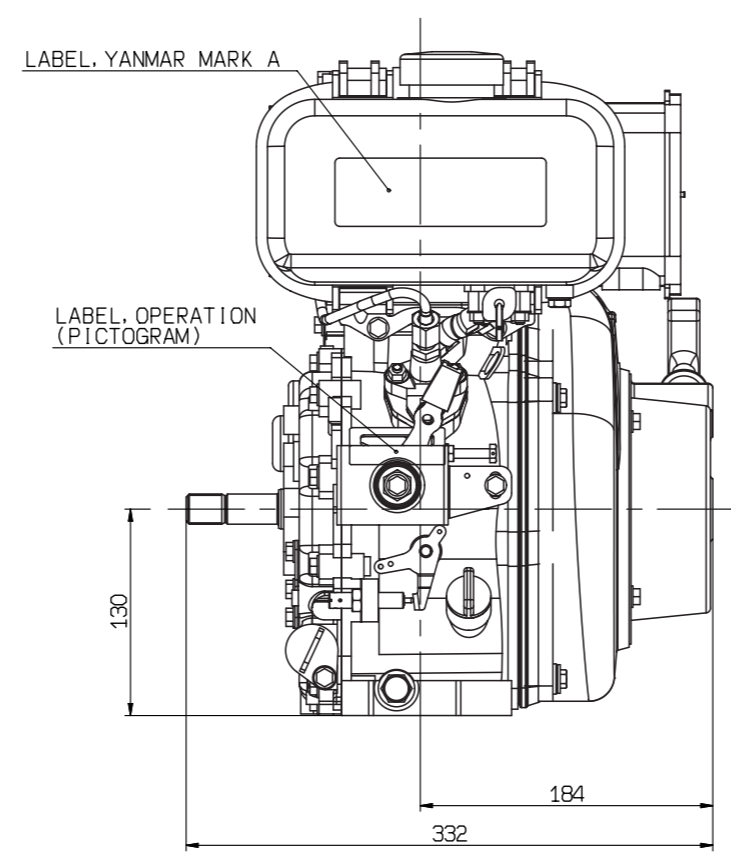
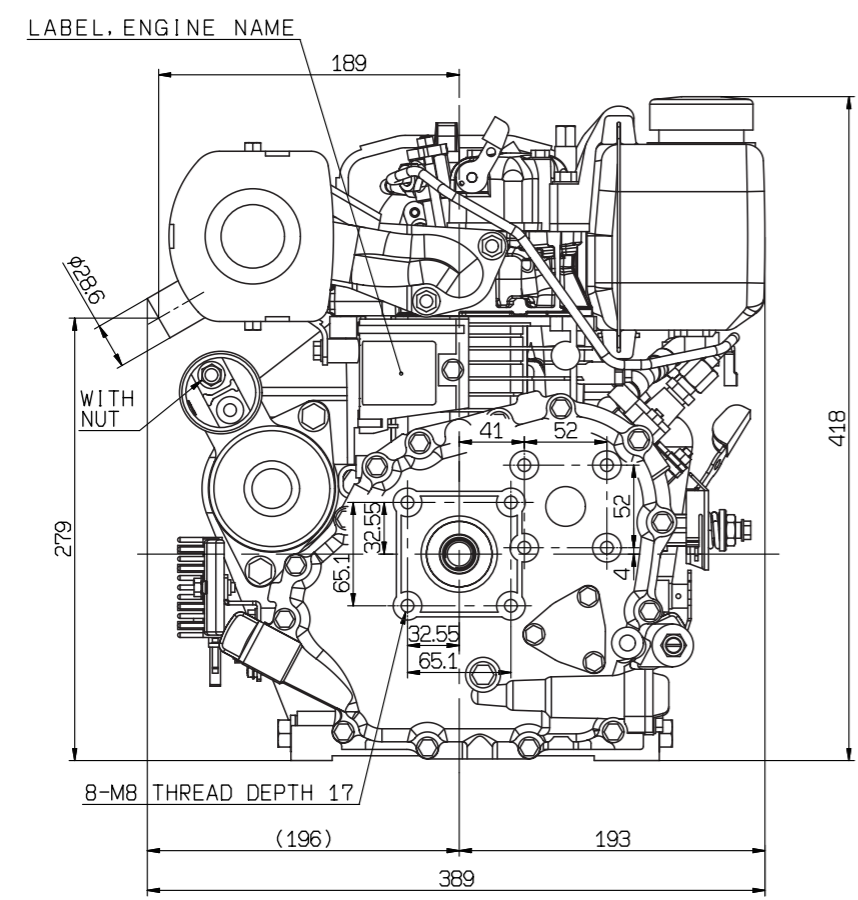

-This outline shows No.1 model as a representative
-No.2 is different from No.1 at FIE parts and FO tank gauge.
-No.3 is different from No.1 at FO limiter and muffler.