



SDEC POWER

D

SERIES

POWER  
GENERATION ENGINES



## G-DRIVE POWERPACK

Power Generation Specification

### TECHNICAL DATA SHEET

#### Power Output Range

230kW – 282kW

STAGE II EMISSION COMPLIANT  
FOR USE IN THE FOLLOWING TERRITORIES. ASIA, MIDDLE EAST AND AFRICA.

## D SERIES DIESEL ENGINE

MODELS	MAX ENGINE OUTPUT		RATED GENERATOR OUTPUT	
	Prime kW	Standby kW	Prime kVA	Standby kVA
6DTAA8.9-G23 (1500 rpm)	230	253	250	275
6DTAA8.9-G23 (1800 rpm)	255	282	275	303

Generator outputs calculated using nett engine power at 0.8 power factor, at an altitude below 1000 m.a.s.l. and 40-degree Celsius ambient temperature. Refer to the outputs and ratings tables for exact site conditions.

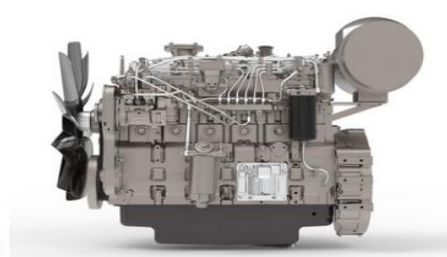

Build specification for export markets

Manufactured in the People's Republic of China

## TECHNICAL ENGINE SUMMARY

SPECIFICATIONS		6DTAA8.9-G23	
Fuel Type	Diesel		
Method Of Cooling	Water Cooled – Set Mounted Radiator		
Number Of Cylinders	6		
Engine Type	Inline 4 Stroke		
Bore x Stroke mm x mm	114 x 144		
Cylinder Liner Type	Wet Liner		
Total Displacement cc / L	8820 / 8.82		
Combustion Type	Direct Injection		
Aspiration - Naturally or Turbo	Turbo Charged		
Make of Turbo Charger	SDEC		
Valves Per Cylinder	4 per cylinder		
Compression Ratio	16.5:1		
Firing Order	1:5:3:6:2:4		
Swept Volume in cm <sup>3</sup>	8819 @ 1500rpm		
Mean Piston Speed in m/min	432 @ 1500rpm	518 @ 1800rpm	
Cyclic Irregularity	0.030-0.038 δs		
Fuel System	Longkou Inline “P” type		
Steady State Speed Stability at Constant Load	G2 Class $\leq \pm 1.5$		
Flywheel & Bellhousing SAE	SAE 2-11.5		
Number of Teeth on Flywheel	125		
Direction of Rotation (Viewed from Flywheel)	Counterclockwise		
Moment of Inertia (Engine and Alternator) kgm <sup>2</sup>	12.0-15.0 kgm <sup>2</sup> depending on the alternator		
Moment of Inertia (Engine) kgm <sup>2</sup>	4.5-6.0 kgm <sup>2</sup>		
PROTECTIONS & SENSORS			
Method of Protection Against High Engine Temperature	KE00105(3/8-18NPT)		
Method of Protection Against Low Oil Pressure	KE21103(NPT1/8;0-10)		
Method of Protection Against Low Water Level	JKE00120 1/2"-G		
Method of Protection Against High Water Temperature	KE00105(3/8-18NPT)		
WEIGHTS & DIMENSIONS			
Weight (Dry) / Weight (Wet) (kg)	740 / 773		
Length x Width x Height (Engine Only) mm	1493 × 792 × 1308		
Length x Width x Height (Engine Only + Radiator) mm	1541 × 945 × 1349		

## RATINGS / OUTPUTS

<b>kW (Gross kWm)</b>	<b>1500</b>	<b>1800</b>
Max kw	253	282
<b>kW (Nett kWm) Rated</b>	<b>1500</b>	<b>1800</b>
Continuous kW	184	204
Prime kW	230	255
Standby kW	253	282
<b>kWe (Nett kWe)</b>	<b>1500</b>	<b>1800</b>
Continuous kWe	175	194
Prime kWe	219	242
Standby kWe	240	268
Based on an alternator efficiency of 95%		
<b>kVA</b>	<b>1500</b>	<b>1800</b>
Continuous kVA @ 0,8pf	200	220
Prime kVA @ 0,8pf	250	275
Standby kVA @ 0,8pf	275	303

These guidelines have been formulated to ensure proper application of generator drive engines in A.C. generator set installations.

### STANDBY POWER RATING

Applicable for supplying emergency power for the duration of the utility power outage. No overload capability is available for this rating. Under no condition is an engine allowed to operate in parallel with the public utility at the Standby Power rating. This rating should be applied where reliable utility power is available. A Standby rated engine should be sized for a maximum of an 80% average load factor and 200 hours of operation per year. This includes less than 25 hours per year at the Standby Power rating. Standby ratings should never be applied except in true emergency power outages. Negotiated power outages contracted with a utility company are not considered an emergency.

### PRIME POWER RATING

Applicable for supplying electric power in lieu of commercially purchased power. Prime Power applications must be in the form of one of the following two categories:

#### UNLIMITED TIME RUNNING PRIME POWER

Prime Power is available for an unlimited number of hours per year in a variable load application. Variable load should not exceed a 70% average of the Prime Power rating during any operating period of 250 hours. The total operating time at 100% Prime Power shall not exceed 500 hours per year. A 10% overload capability is available for a period of 1 hour within a 12-hour period of operation. Total operating time at the 10% overload power shall not exceed 25 hours per year.

#### LIMITED TIME RUNNING PRIME POWER

Limited Time Prime Power is available for a limited number of hours in a non-variable load application. It is intended for use in situations where power outages are contracted, such as in utility power curtailment. Engines may be operated in parallel to the public utility up to 750 hours per year at power levels never to exceed the Prime Power rating. The customer should be aware, however, that the life of any engine will be reduced by this constant high load operation. Any operation exceeding 750 hours per year at the Prime Power rating should use the Continuous Power rating.

### CONTINUOUS POWER RATING

Applicable for supplying utility power at a constant 100% load for an unlimited number of hours per year. No overload capability is available for this rating.

### NB: DC VARIABLE SPEED POWER RATING

Please consult with engineering for applications where variable speed engines are required for D.C. generator set applications.

**RATINGS – DERATION CURVES**

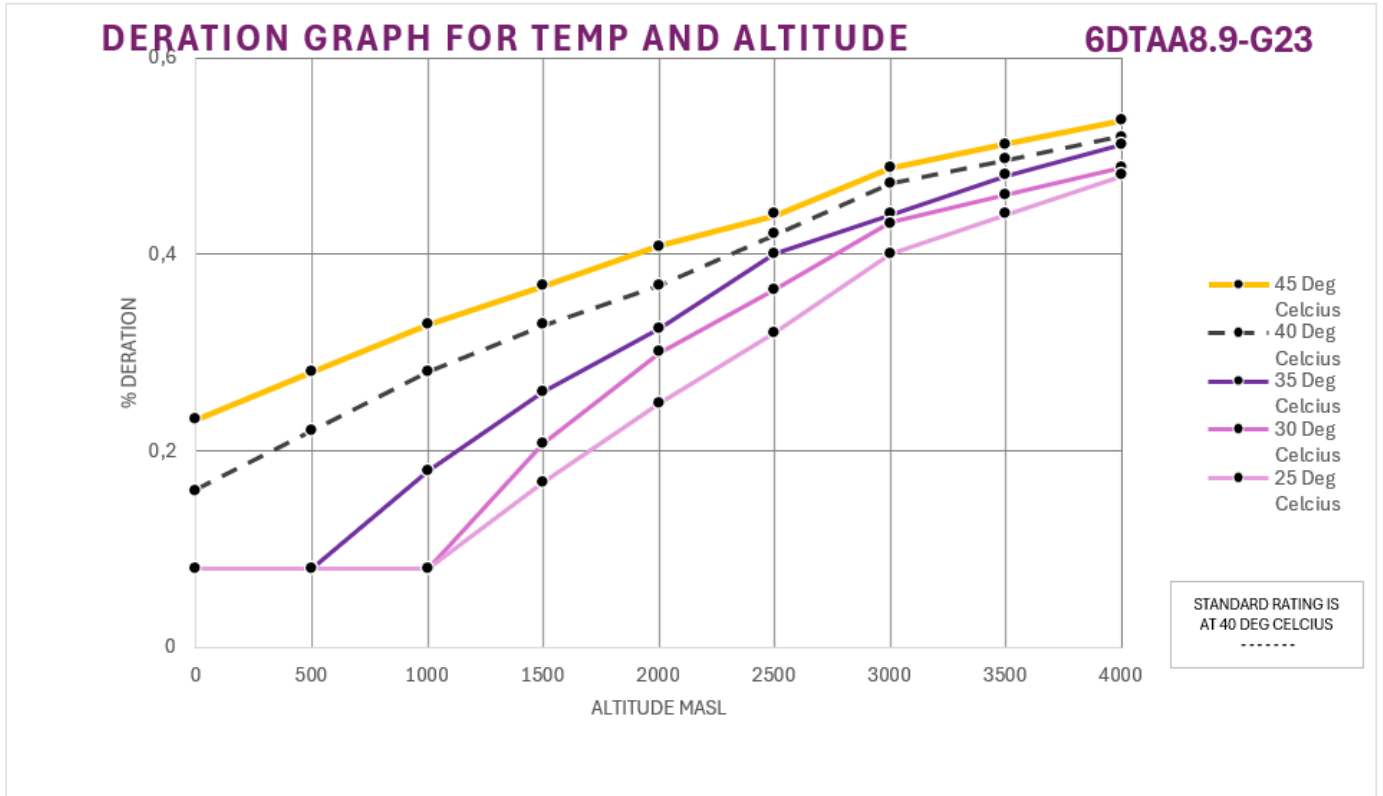

Alt.	500	1000	1500	2000	2500	3000	3500	4000
<b>Temp</b>								
<b>50 Deg C</b>	-	-	-	-	-	-	-	-
<b>45</b>	28%	33%	37%	41%	44%	49%	51%	54%
<b>40</b>	22%	28%	33%	37%	42%	47%	50%	52%
<b>35</b>	8%	18%	26%	32%	40%	44%	48%	51%
<b>30</b>	8%	8%	21%	30%	36%	43%	46%	49%
<b>25</b>	8%	8%	17%	25%	32%	40%	44%	48%

**TEST CONDITIONS**

Air temperature. . . . . 27 °C  
 Barometric pressure. . . . . 100 kPa  
 Relative humidity . . . . . 30%  
 Air inlet restriction at maximum power (nominal) . . . . . 2,5 kPa  
 Intercooler Pressure at maximum power (nominal) . . . . . 2,5 kPa  
 Exhaust back pressure at maximum pressure (nominal) . . . . . 3,0 kPa  
 Fuel temperature (inlet pump) . . . . . 55 °C maximum

**Notes:**

All data is based on the engine operating without, alternator, optional equipment and driven components. Data shown above represents gross engine performance capabilities obtained and corrected in accordance with GB/T1147.1-2017 and Equivalent ISO 3046-1:2002

Standards for ratings (continuous, prime, standby) in accordance with GB/T2820 and Equivalent ISO 8528-1:2018

## LOAD ACCEPTANCE AND GOVERING CLASS

Initial load acceptance					
When engine reaches rated speed					
(Withing 15 seconds after engine starts to crank)					
Step Load	Prime Power Load kWm	Load kW <sub>e</sub> nett	Expected frequency deviation %	Frequency recovery time seconds	Frequency stability
25% - 75%	58 – 173	72 – 216	3-5% dip	≤ 5-8	± 0.5%
0% - 100%	0 – 230	0 – 253	5-7% dip	≤ 8-12	± 0.5%
100 – 0% load drop	230 - 0	253 – 0	5-6% overshoot	≤ 3-6	± 0.5%

## VALVES AND MECHANICS

### VALVE MECHANISM

Type	Overhead Valves
Number of Valves	2 Intake & 2 Exhaust / per Cylinder
Valve Latches when Cold	Intake 0.30mm
	Exhaust 0.50mm

### VALVE TIMING

	OPENING	CLOSE
Intake Valve	29.5 ° BTDC	42.5 ° ABDC
Exhaust Valve	69.5 ° BBDC	34.5 ° ATDC

## ELECTRICAL SYSTEM

### CHARGING ALTERNATOR

Charging Alternator Manufacturer	SDEC- D11-102-13
Charging Alternator	55 A x 28V
Voltage Regulator	Built-In IC Regulator

### STARTER MOTOR

Starter Motor Manufacturer	SDEC- S00022618
Number of Starter Motors	1
Starter Motor Power	7.5 kW
Starter Motor Voltage	24 V

### BATTERIES (NOT SUPPLIED / RECOMMENDED)

Battery Capacity	180 Amp-Hour
Number of Batteries & Type	2 x 12V Lead Acid

## FUEL CONSUMPTION

MODEL	LOAD				
	25%	50%	75%	100%	110%
1500 rpm g/kWh	58	101	149	201	223
1500 rpm l/h	16	28	41	55	61
1800 rpm g/kWh	62	106	152	208	232
1800 rpm l/h	19	32	46	63	70

## FUEL SYSTEM

### Injection System

Type	Electronic
Injection Pump	Longkou in-line "P" type
Injection Nozzle	Multi-Hole Type
Opening Pressure	250 kg/cm <sup>2</sup>
Injection Timing	8.5 °BTDC
Feed Pump	Mechanical
Governor	Electronic regulator
Governing Class	G2
Speed Controller	Fortrust C2004

### Fuel Filtration

Fuel Filter	Spin On Type
Fuel Filters Type	Full Flow Cartridge
Fuel Filters	1 Primary
Water Separator	Optional

### Fuel

Fuel Type	Diesel
Suggested Grade / Class	50 ppm or better
Bio Diesel Compatible	Confirm the ratio with the factory before use

## LUBRICATION SYSTEM

### Oil Lubrication System

Lubrication Method	Fully forced pressure feed type
Oil Pump Type	Gear type driven by crankshaft

### Oil Pan Capacity

High Level / Low Level (Litres)	25 / 22
---------------------------------	---------

### Angularity limit

Front Down	25 °
Front Up	35 °
Side to Side	35 °

### Oil Filtration

Oil Filter	Spin On Type
Oil Filters Type	Full Flow Cartridge
Oil Filters	1 Primary

### Oil

Oil Type	Multigrade Oil
Suggested Grade / Class	CH 15W/40

## ENGINE COOLING DATA AND THERMODYNAMICS

Cooling System		Heat Rejection	
Cooling Method	Fresh Water Forced Circulation	Heat Rejection to Coolant	23kcal/sec (1500 rpm) 26kcal/sec (1800 rpm)
Water Capacity (Engine Only)	12 litres	Heat Rejection to Intercooler	15kcal/sec (1500 rpm) 16kcal/sec (1800 rpm)
Water Lid Min. Pressure	70 kPa	Max. Permissible Restrictions	3kPa
Water Pump	Centrifugal Type	Permissible Restrictions: Intercooler	8kPa
	Belt Driven	Intake System kPa	6kPa
Water Pump Capacity 1500 rpm	200 L/min	Max. Permissible Altitude m.a.s.l.	2000m
Water Pump Capacity 1800 rpm	240 L/min	Exhaust System	
Thermostat	Wax-Pellet Type	Exhaust Gas flow	32m <sup>3</sup> /min (1500 rpm) 40m <sup>3</sup> /min (1800 rpm)
	Opening Temp. 82°C	Exhaust Gas Temperature Max °C	600°C
	Full Open Temp. 93°C	Exhaust Outlet Size (Internal) mm	Ø95.5
Cooling Fan Type	Blower Type-Plastic	Exhaust Outlet Flange Size mm	Ø150
Drive Type	Mechanically Driven	Exhaust Flange & Bellow Supplied	No
Cooling Fan Construction	10 x Plastic Blades	Back Pressure for Total System at Standby Power	10 kPa Max
Cooling Fan Size	762 mm Diameter	Exhaust Smoke (FSN)	≤2.5
Cooling Fan Power Consumption	6kW	Turbo Charger	
Cooling Air Flow	6.2 m <sup>3</sup> /s	Manufacturer	SDEC
		Boost Pressure Ratio	16.5:1
Radiator		Water Jacket Cooling Data (Optional)	
Type	Set Mounted	Coolant Flow - litres/min	5l/min
Manufacturer	LK	Coolant Exit Temperature (max) °C	70-85 °C
Construction	Copper Core	Coolant Inlet Temperature (min) °C	-40 °C
Treatment	Tropicalised	Coolant Inlet Temperature (max) °C	+60 °C to +70 °C
Temperature	50 Degree	Suggested Pump Rating kW	1 kW
Intercooled	Yes		
Antifreeze		Colour of the engine	
Fuel Type	Premix (50/50)	RAL(Colour)	RAL 9006 (White/Silver Aluminium)
Compliant Grade / Class	ASTM D-3306 ASTM D-6210 SAE J814		
Main Ingredient	50% Glycol or More		

**SIDE VIEW - RHS**

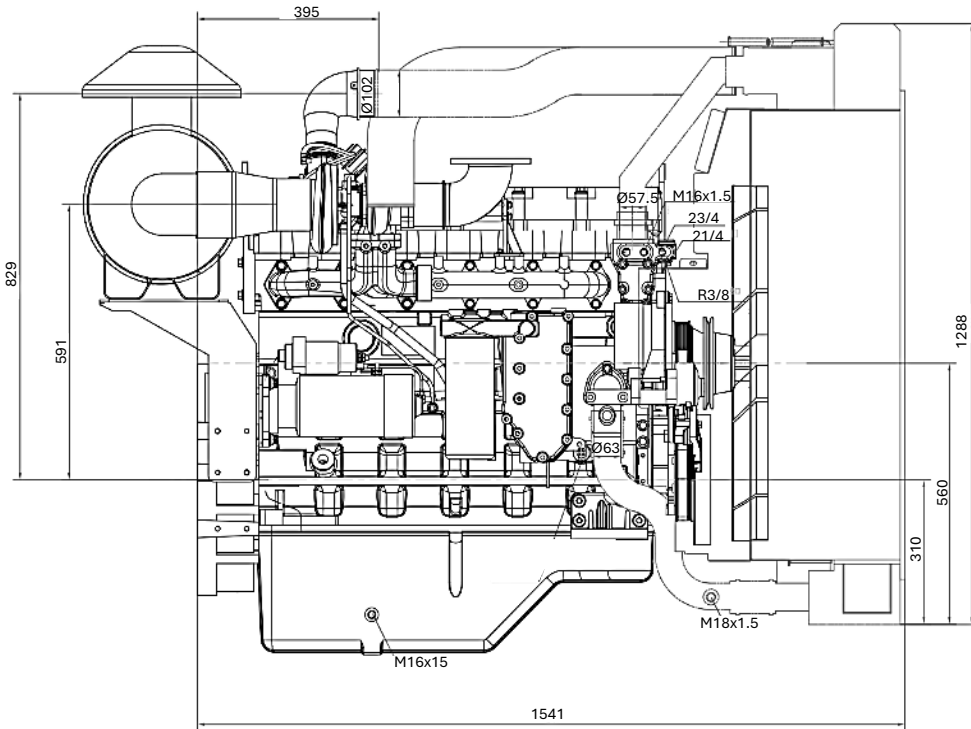

**SIDE VIEW - LHS**

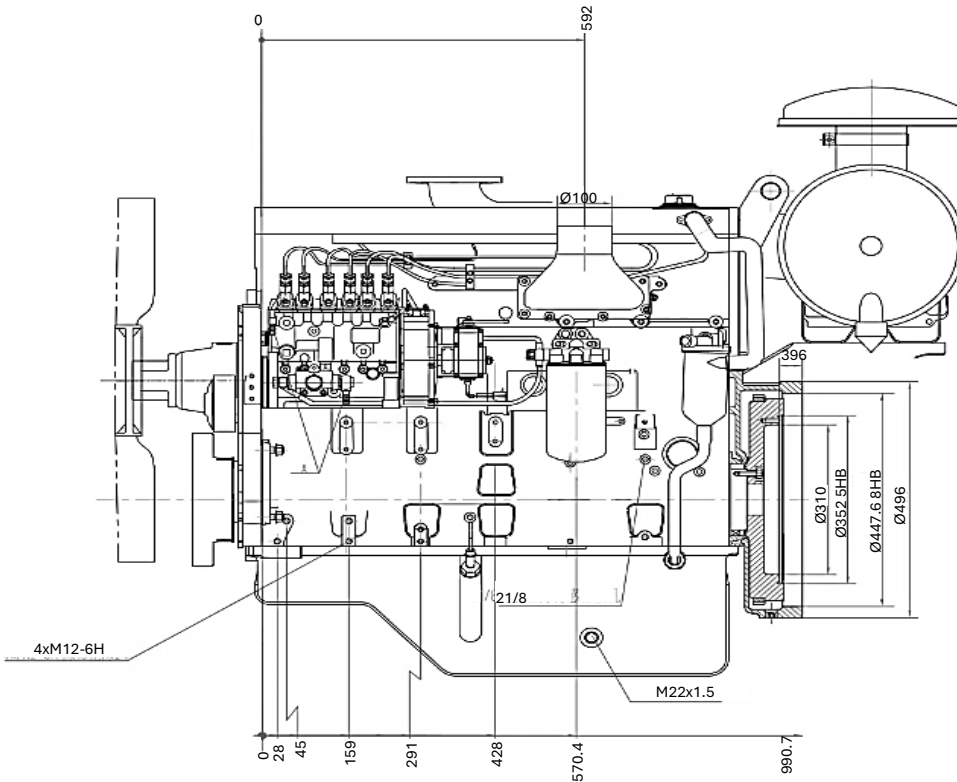

**FRONT VIEW- FAN**

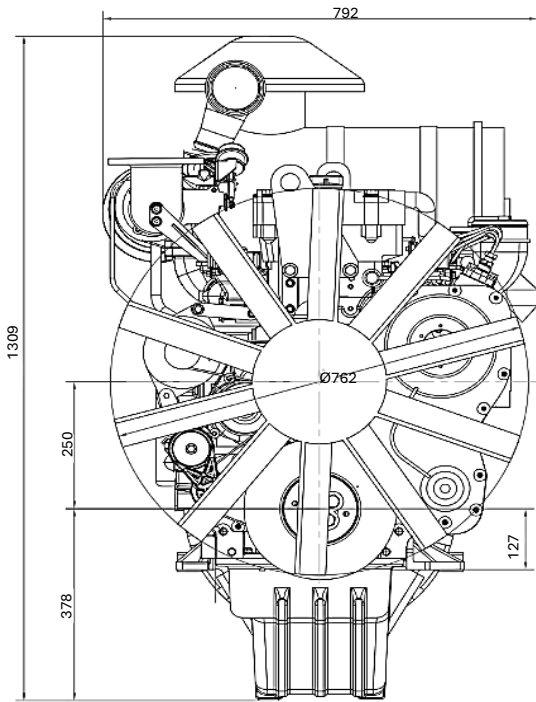

**TOP VIEW - AERIAL**

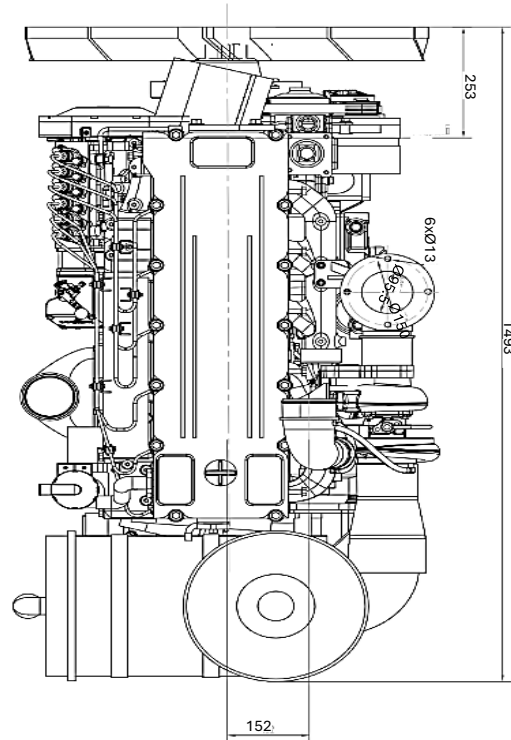

**REAR VIEW - FLYWHEEL**

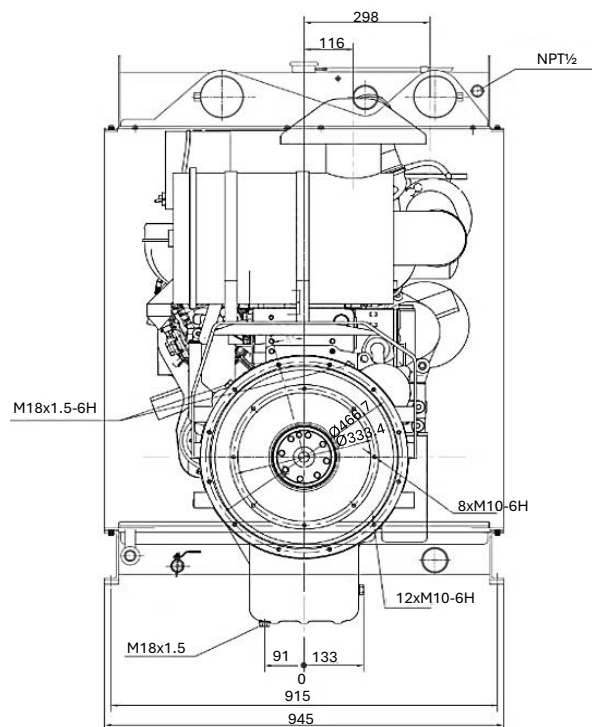

## SERVICE AND CRITICAL PARTS

SERVICE HOURS		50	100	250 Monthly	1000 Annually
SERVICE PART	PART NO.				
Air Filter (Inner)	4050131	-	-	Yes	Yes
Air Filter (Outer)	-	-	-	-	-
Fuel Filter (Outer)	2040112	-	-	Yes	Yes
Fuel / Water Separator	-	-	-	-	-
Oil Filter	2040111	-	-	Yes	Yes
Fan Belt	D16A-106-900	Check wear or damage	Check wear or damage	Check wear or damage	Yes
Timing Belt	-	-	-	-	-
Oil	CH 15W/40	Check Level	Check Level	Yes	Yes
Anti-Freeze	50/50 (Premix)	Check Level	Check Level	Check Level	Check Level
CRITICAL PARTS					
SERVICE PART	PART NO.				
Charging Alternator	D11-102-23				
Starter Motor	S00022618				
Valve Cover Gasket	D04-135-901				
Exhaust Gasket	S00001858				
Radiator	S00028059				
Speed Controller / ECU	ESG2002A800C-W				
Turbocharger	S00008689				
Lift Pump	Provide engine build no				
Fuel Pump	S00004227				
Oil Pump	D15-000-900				

